

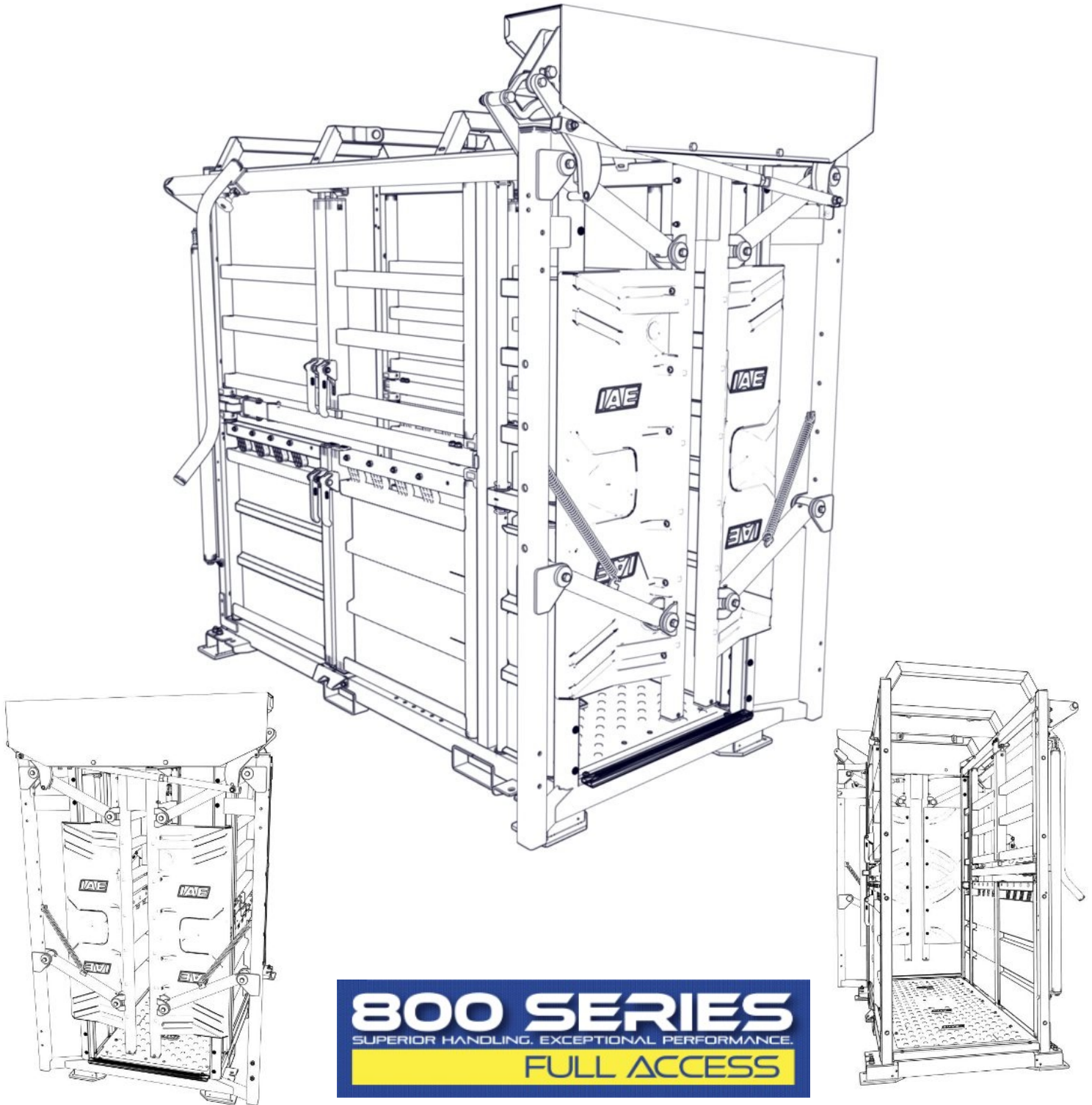

800 SERIES

MANUAL

Call: +44 (0)1782 339320 | Email: sales@iae.co.uk | Weblink: <https://iae.co.uk/>



800 SERIES (B21) MECH YOKE ACCESS CRUSH

INSTALLATION, OPERATION & MAINTENANCE

TECHNICAL DOCUMENT NO. 1003598-01

PRODUCT 1002396-01 KEY FEATURES

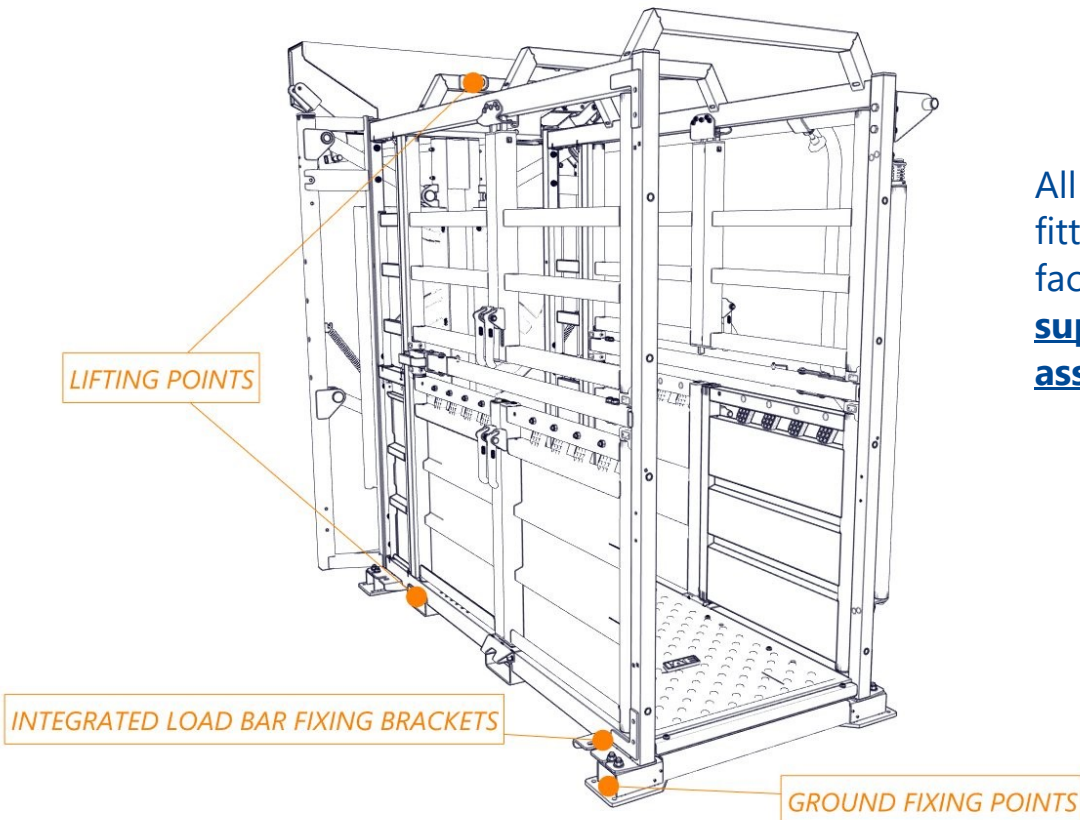
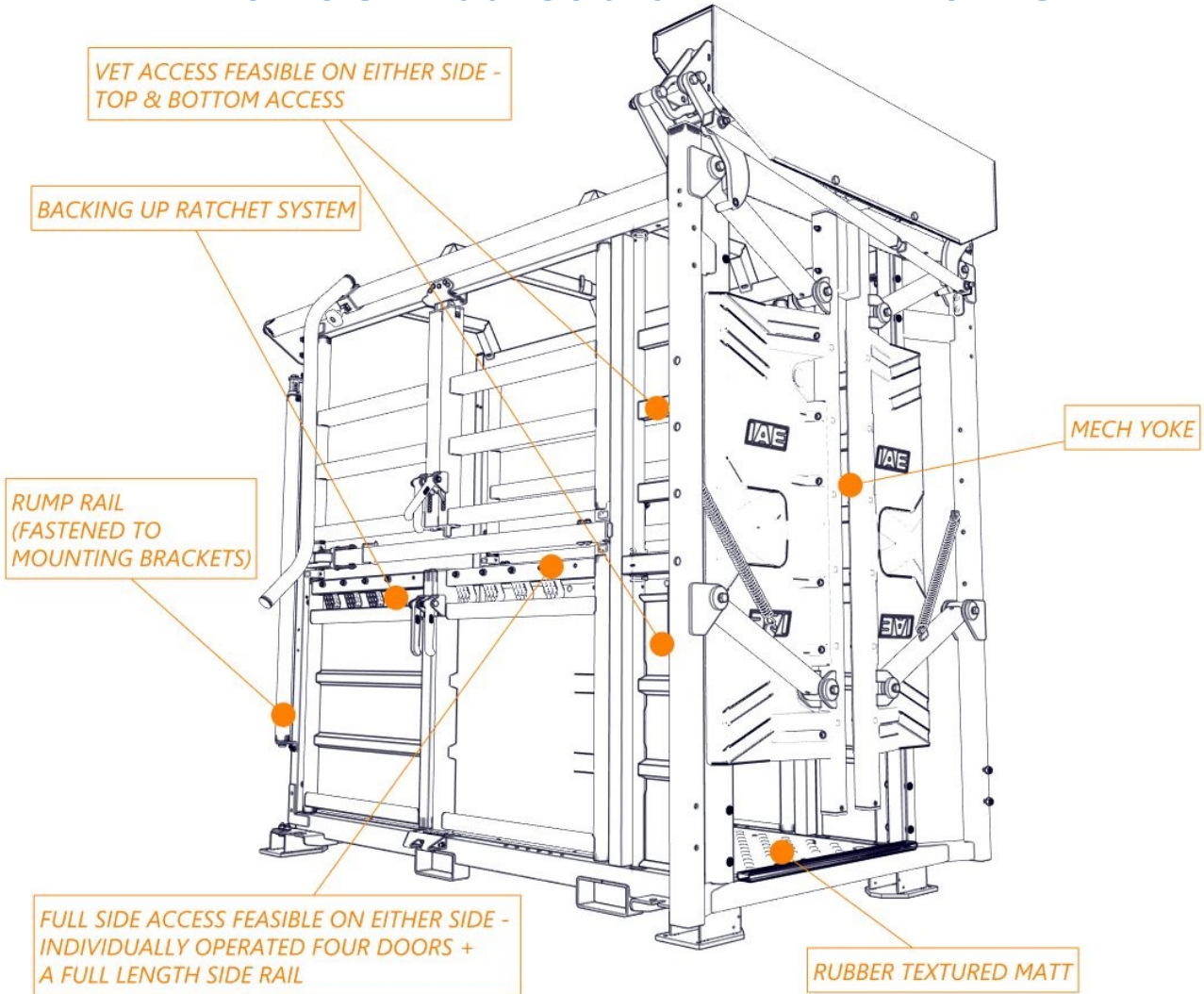

All features listed are fitted together at the factory and will be **supplied fully assembled.**

INTENDED USE

A heavy-duty restraining device that holds big, heavy and strong animals like cattle so that work force (including veterinarians) can work with them. It is close fitting and simply keeps the animals from moving, which keeps both the cattle and workers safe.

TECHNICAL DATA

Item Number: 1002396-01

Load: 1000 Kg Max.

Weight: 600 Kg

Dimensions (W x H x D): 1590 x 2250 x 2950 Approx.

MECH YOKE

Manual yoke controlled by personnel (lever operated) using scissor action to yoke - is designed for use on herds with varying sizes of cattle more suited and beneficial to herds who are frequently handled, of a more subdued nature and used to being restrained in the yoke. Mech yoke features include,

- ❑ NEW DESIGN Friction locking mechanism for smoother operation (option to easily replace brake box if worn)
- ❑ Manually operated by a lever (on right hand side) - simple scissoring movement (operating lever can be situated anywhere along the side of the crush)
- ❑ Full length HDPE moulded baffle plates fitted as standard to prevent leg trapping
- ❑ Option to convert to opposite hand operated if needed (on site assembly required)

COMPATIBLE WITH IAE OPTIONS TO FIT

- ✓ CRUSH EXTENSION - 1002145-01
- ✓ SLIDING GATE IN FRAME - 1001686-01
- ✓ M800 SCOOP BRACKET - 1003654-01
- ✓ 800 SERIES ID READER KIT - 1003656-01
- ✓ HOOFF TRIMMING KIT - 1002393-01
- ✓ STERNUM BAR KIT - 1002705-01
- ✓ FRONT CAGE - 1003642-01
- ✓ LOAD BAR

(All options to fit supplied separate with onsite assembly required, to be organized by customer/operator)

SAFETY INFORMATION

PLEASE TAKE NOTE OF THE FOLLOWING SAFETY PRECAUTIONS BEFORE USE FOR THE WELLBEING OF ALL ANIMALS AND PERSONNEL. ANY HARM OR INJURY WHICH OCCURS FROM THE LACK OF COMPLIANCE WITH THESE HEALTH AND SAFETY MEASURES WILL BE THE RESPONSIBILITY OF THE OPERATOR.

- ❑ **IMPORTANT!** Read these instructions carefully before use and keep them for future reference. The safety of your animals may be affected if you do not follow these instructions in this manual.
- ❑ **WARNING! DANGER TO LIFE AND RISK OF ACCIDENTS FOR INFANTS AND CHILDREN!** Keep children away from the product when in operation.
- ❑ Situate this product on a level, solid surface.
- ❑ **WARNING!** Be careful with hands, fingers and limbs when operating the crush.
- ❑ Personal protection may be required for some stages of installation, and/or operation.
- ❑ **CAUTION!** When handling heavy equipment, some stages of installation may require at least two people.
- ❑ **DO NOT** lean on or exert undue pressure on the product.
- ❑ **CAUTION!** Check posture when lifting/manoeuvring the equipment or associated parts.
- ❑ **ALWAYS** Check the product for damage before each use.
- ❑ **NEVER USE THE PRODUCT IF IT IS DAMAGED.**

If you have any questions or comments regarding the product, we will be glad to hear them either through our website www.iae.co.uk or by contacting your local IAE dealership.

INTRODUCTION/PRODUCT FEATURES	Page 2
INTENDED USE	Page 3
TECHNICAL DATA	Page 3
COMPATIBLE WITH IAE OPTIONS TO FIT	Page 3
SAFETY INFORMATION	Page 4
CRUSH INSTALL/GROUND FIXING	Page 6
HOW TO OPERATE	
OPERATING AUTO YOKE	Page 7
YOKE APERTURE ADJUSTMENT GUIDE	Page 9
OPERATING SIDE DOORS	Page 10
OPERATING FULL LENGTH SIDE RAIL	Page 10
OPERATING VET ACCESS PANELS	Page 11
REMOVING VET ACCESS PANELS	Page 11
PIVOTING VET ACCESS TOP PANEL	Page 12
OPERATING RUMP RAIL	Page 13
RECOMMENDED MAINTENANCE	Page 15
CONTACT	Page 15

CRUSH FIRST USE/GROUND FIXING

- ❑ Locate on firm and level ground, IAE recommend placing onto a concrete pad.
- ❑ Allow for sufficient space all around the crush for safe operation.
- ❑ It is advised to run through the operations of the crush without cattle present to familiarise yourself with the correct workings.

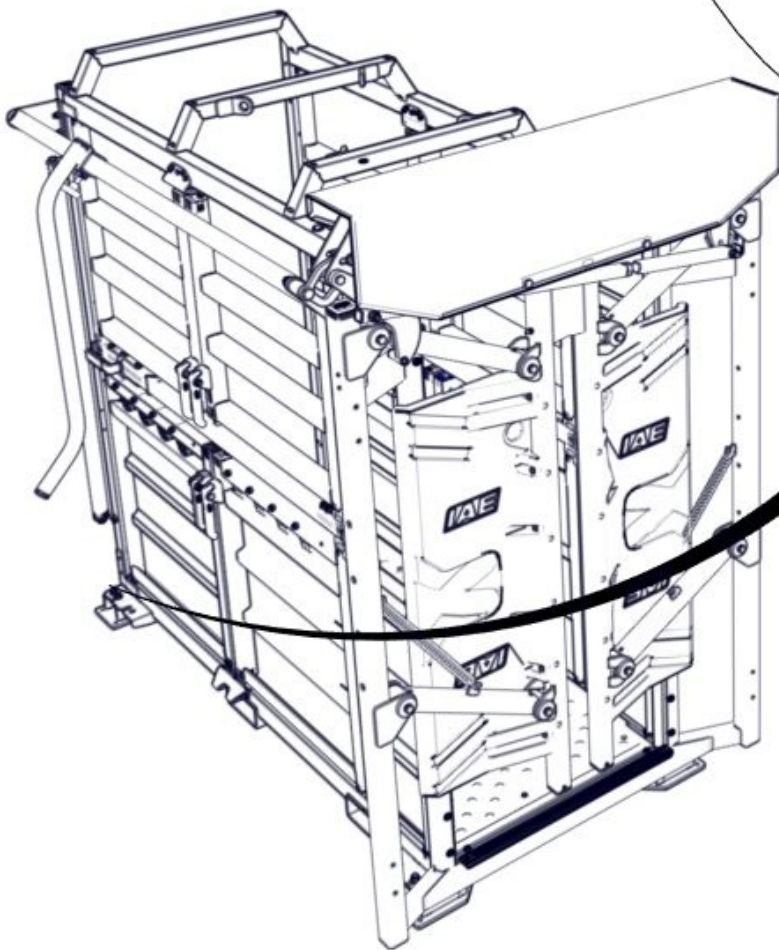
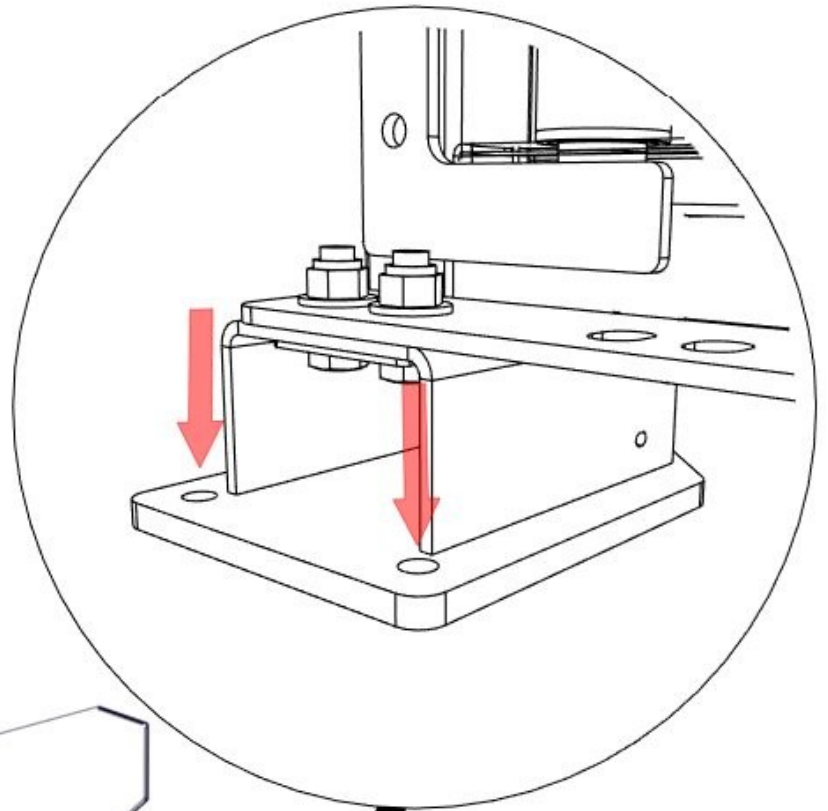

Ground fixing instructions:

Utilise the feature of the bolt on feet (fitted in each corner) for fixing into ground, particularly when the product is to remain situated in one permanent location.

OPERATING MECH YOKE

Begin in position, **LOCKED**

(yoke doors inline)

800 SERIES(B21) MANUAL YOKE OP' HANDLE

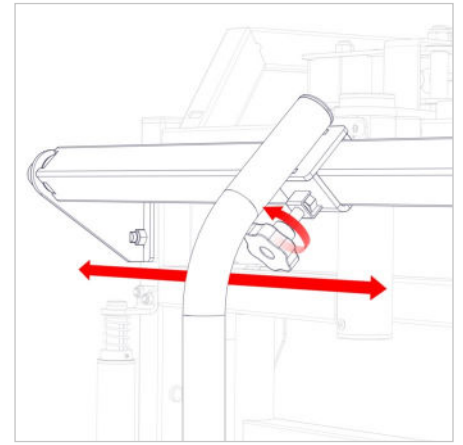

800 SERIES B21 MANUAL YOKE ARM (UPPER LH & RH)

CAUTION: *op' handle can be positioned anywhere along the side body, IAE recommend rear operating as best practice*

800 SERIES (B21) HDPE MOULDED BAFFLE

800 SERIES(B21) MANUAL YOKE ARM (LOW LH & RH)

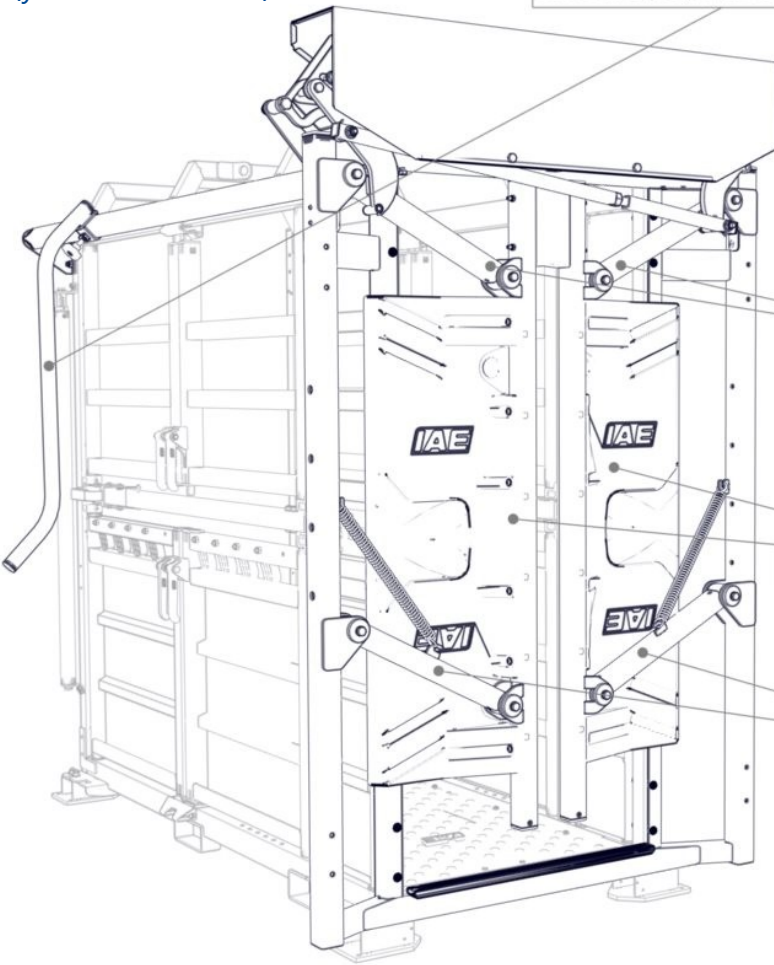

Instruction: lift handle to activate release.

READY TO RECEIVE

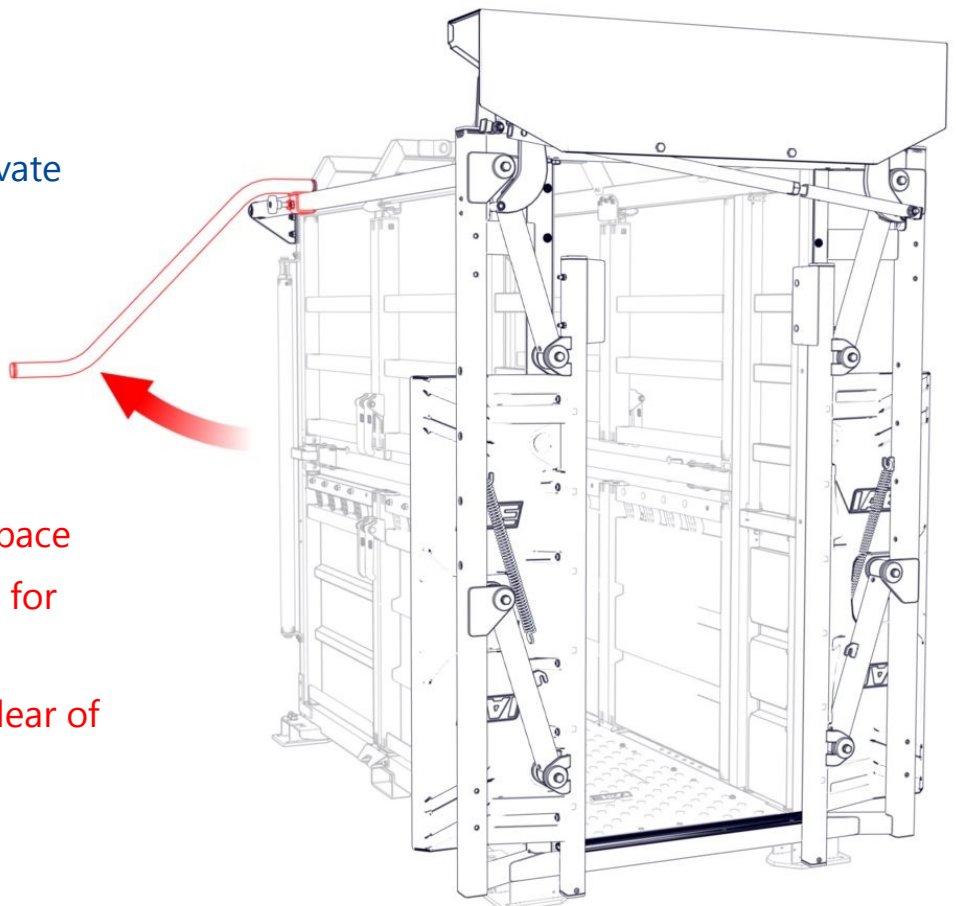

CAUTION: Allow sufficient space around the entire crush body for operating safely, keep fingers and limbs well clear of any moving parts.

Instruction: allow animal to enter the chute, at the point when its head and neck are positioned past the yoke doors, the operator can activate the yoke by lowering the operating handle.

ANIMAL YOKED

CAUTION: Do not enter the area in front of the crush until you are certain the animal is fully secured.

Note: arrow & circle indicate animal travel direction and head position when yoked.

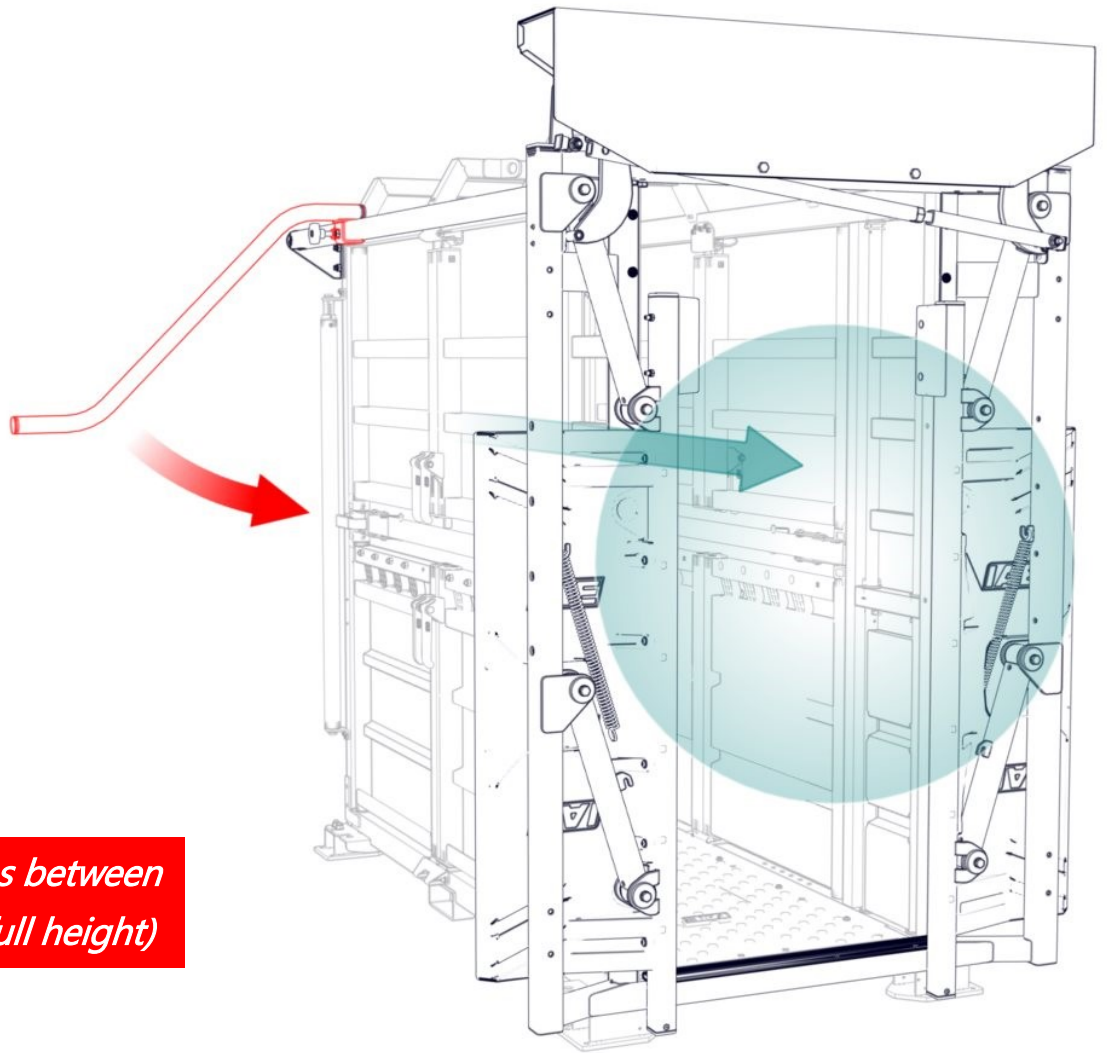

Yoke aperture ranges between 760mm—100mm (full height)

Instruction: lift operating handle to release.

ANIMAL RELEASED

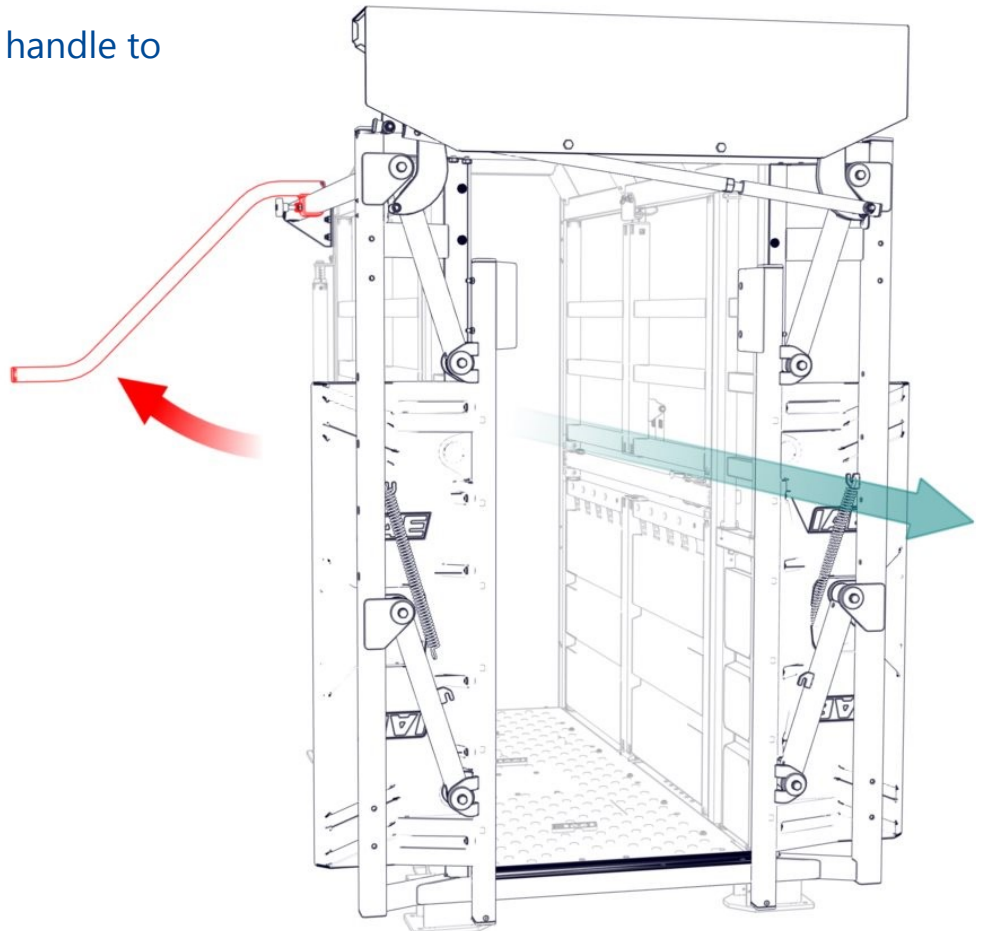

OPERATING SIDE DOORS

Instruction: lift bolt pivot handle to release
(four doors individually operated)

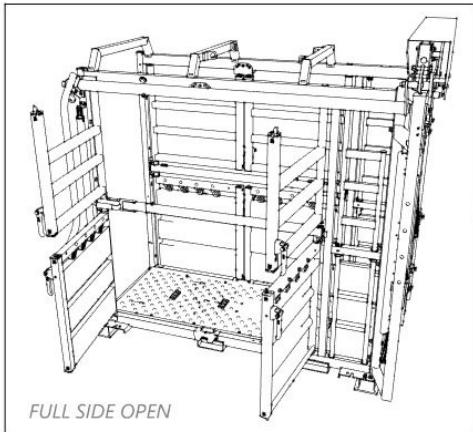
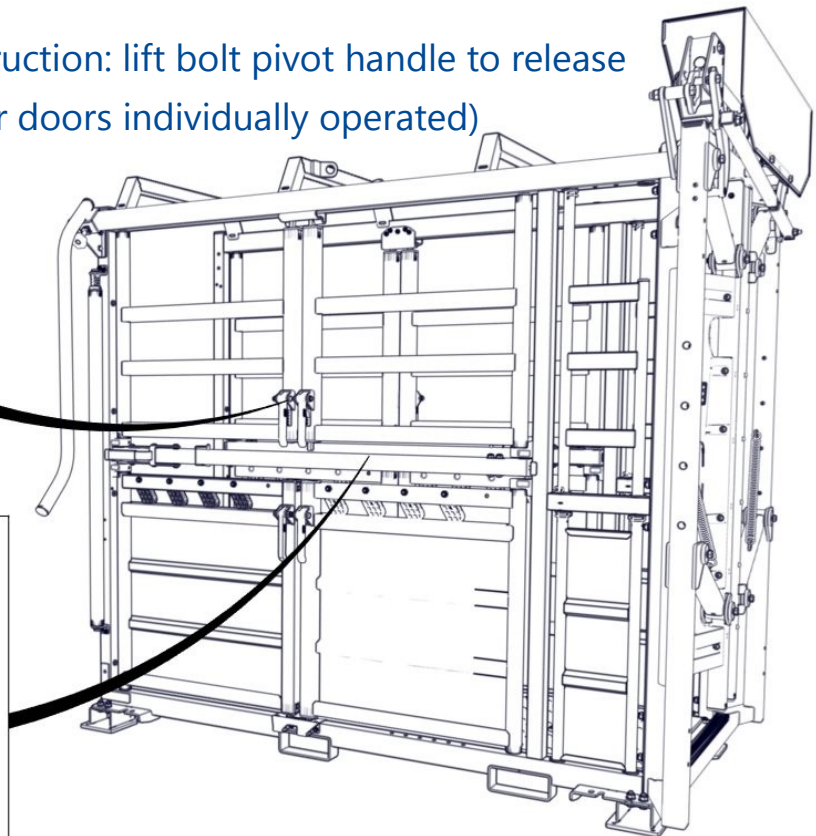
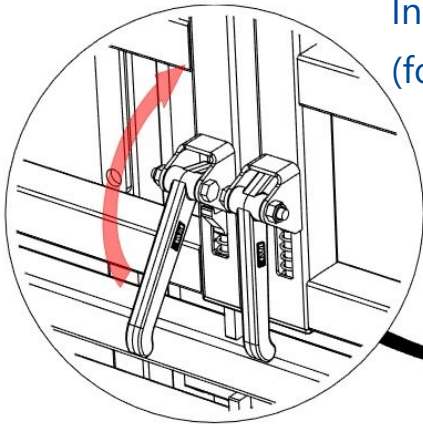

CAUTION: Restricted opening due to mech yoke
op. handle reposition as required

OPERATING FULL LENGTH SIDE RAIL

(removed for entire side access)

Instructions: pull operating handle to
release and lift rail away to free, place
loose rail away from the crush when
not in use.

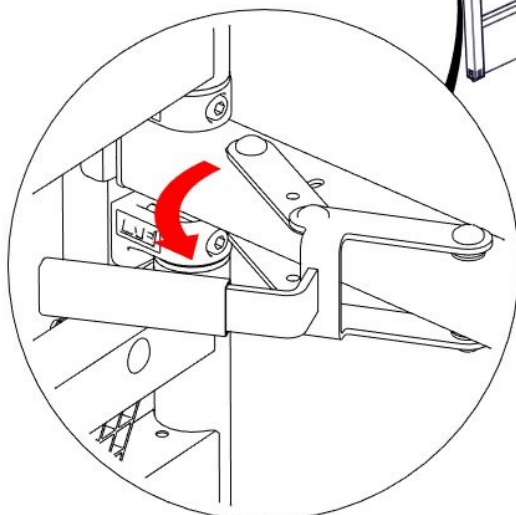
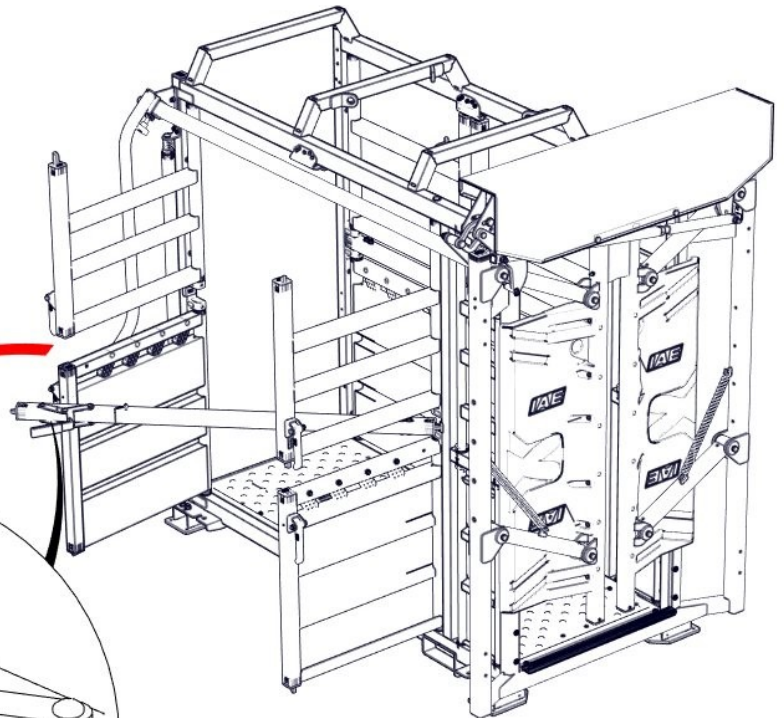

Option to reverse the side rail
(situating the side rail operating handle
locking into the front end main body
pillar, adjacent to vet access)

OPERATING VET ACCESS PANELS

Duplicate vet access panels on opposite side, all with capability to remove when access is required.

800 SERIES(B21) ACCESS CRUSH VET ACCESS
(TOP FOR TB TESTING)

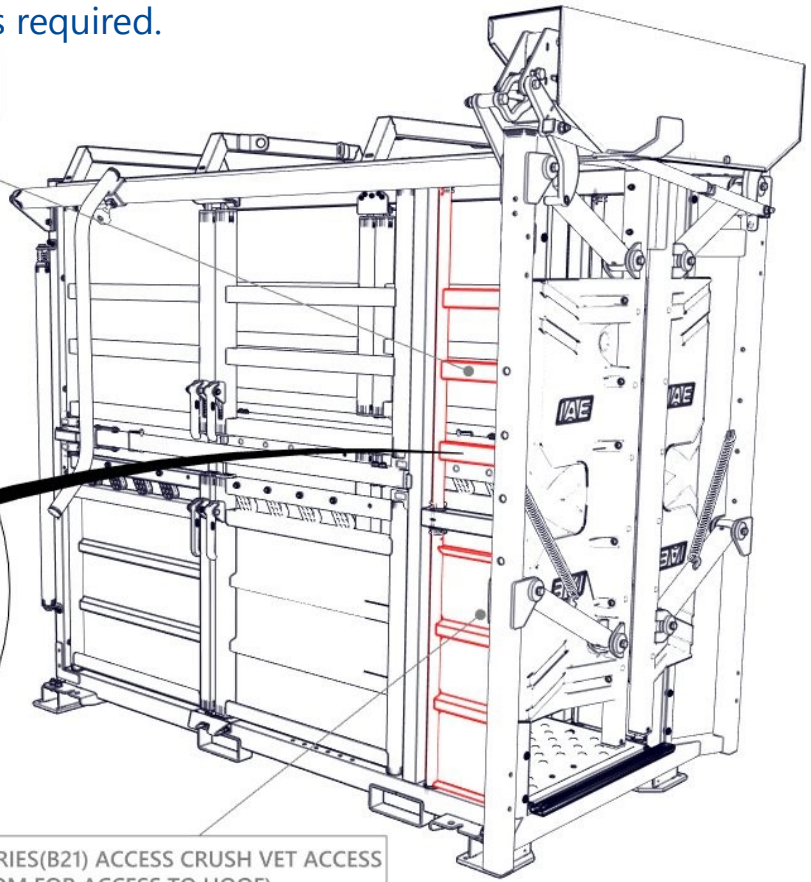
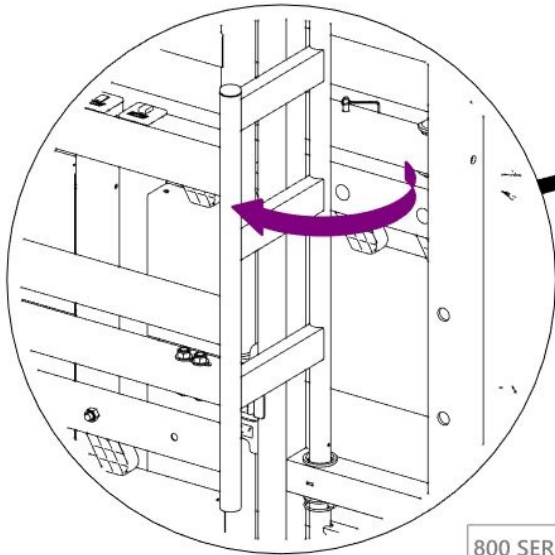

800 SERIES(B21) ACCESS CRUSH VET ACCESS
(BOTTOM FOR ACCESS TO HOOF)

REMOVING VET ACCESS PANELS

Instruction: remove locking pins.

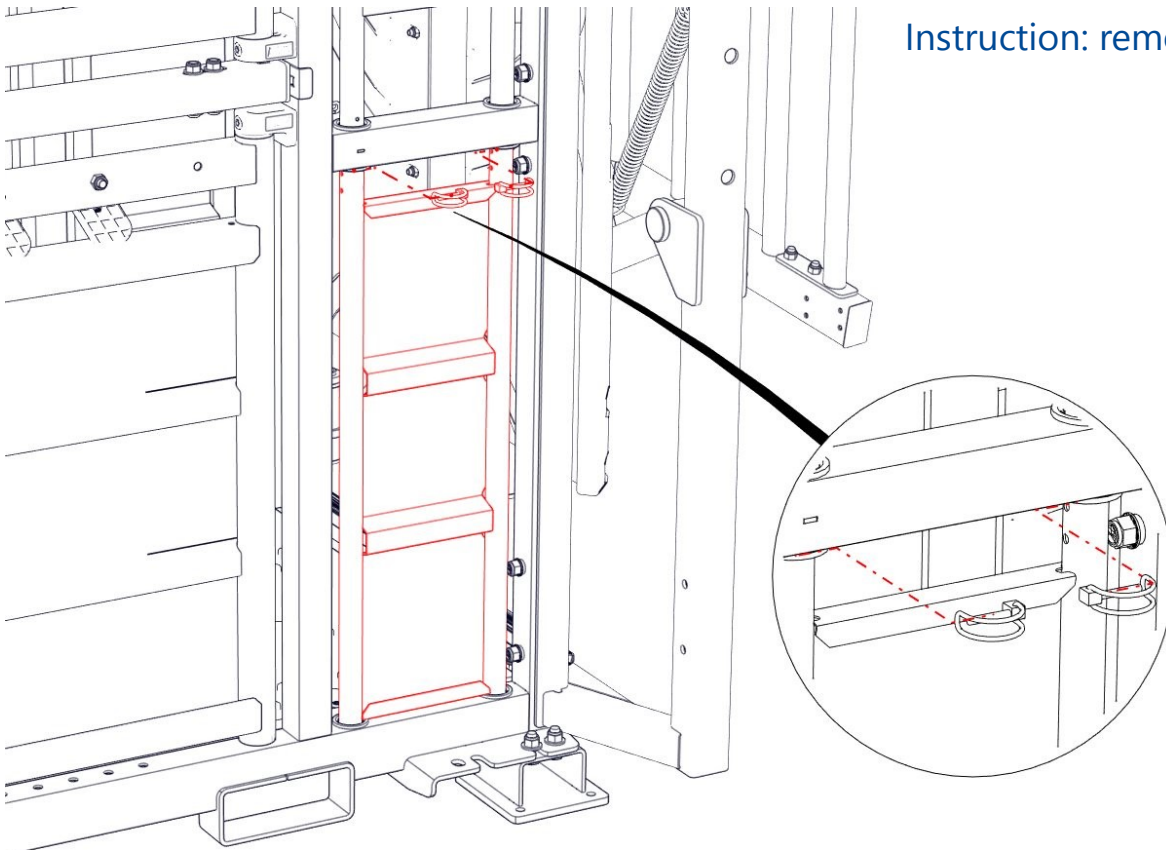

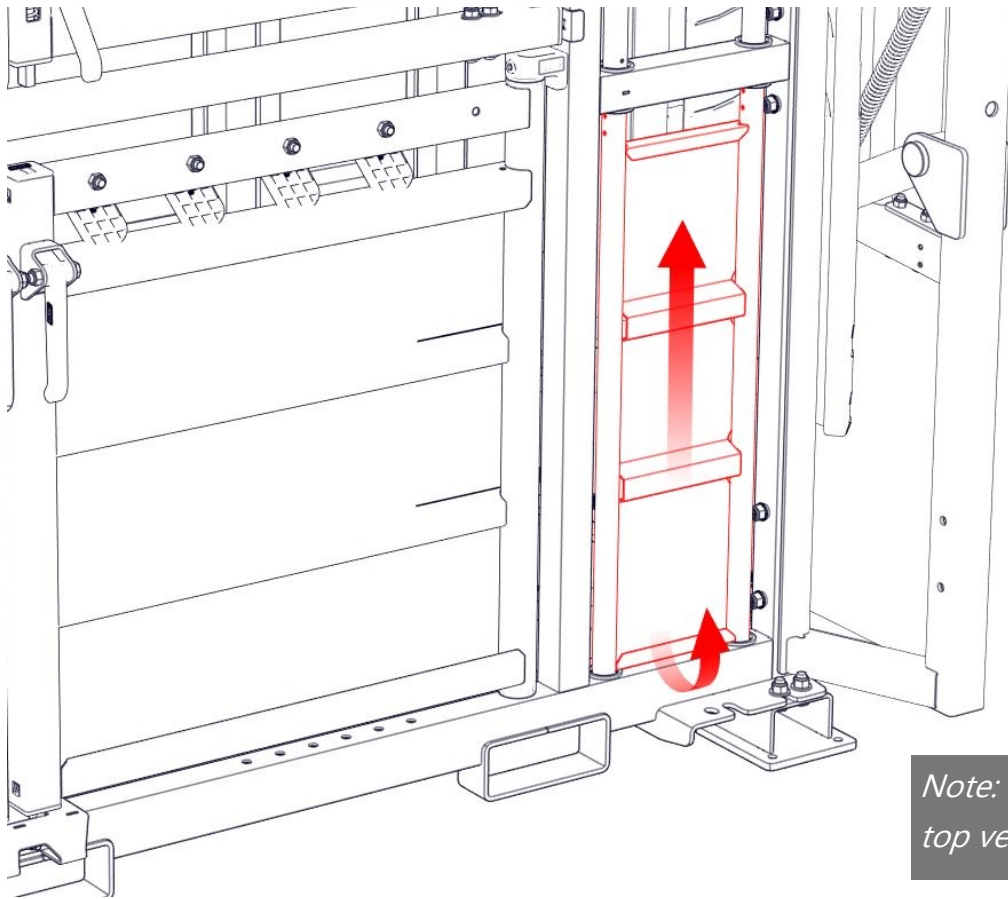

Instruction: lift (so tube end is free from bushes) and lift away to fully remove the panel.

Note: instructions for removal of the top vet access are the same .

PIVOTING VET ACCESS TOP PANEL

Instruction: relocate pin, move to lowest hole. allowing panel to be lifted above bushes.

Swing to open.

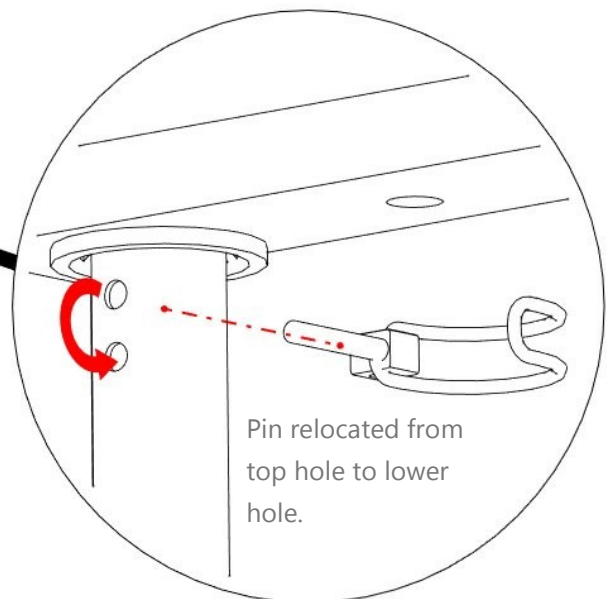
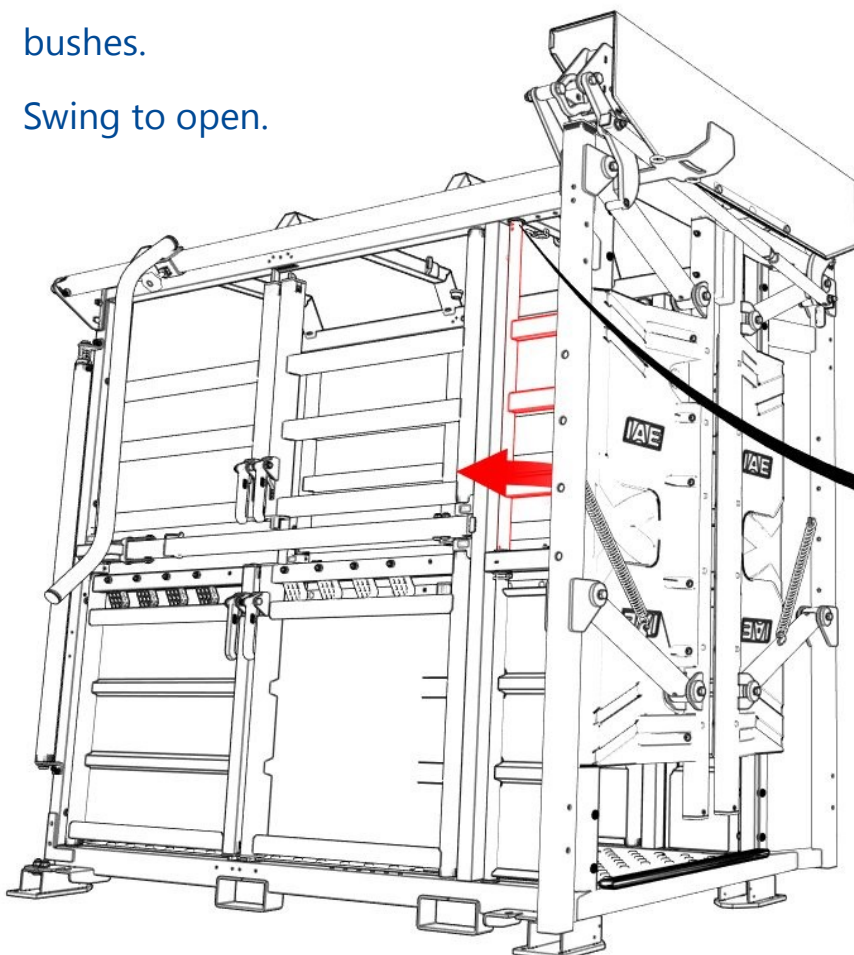

Pin relocated from top hole to lower hole.

OPERATING RUMP RAIL

Mounting brackets provided bolt-on, can be moved to opposite side if required. (main body frame is pre-drilled to suit).

Instruction: push up and pull out to eject rump rail from mounting bracket.

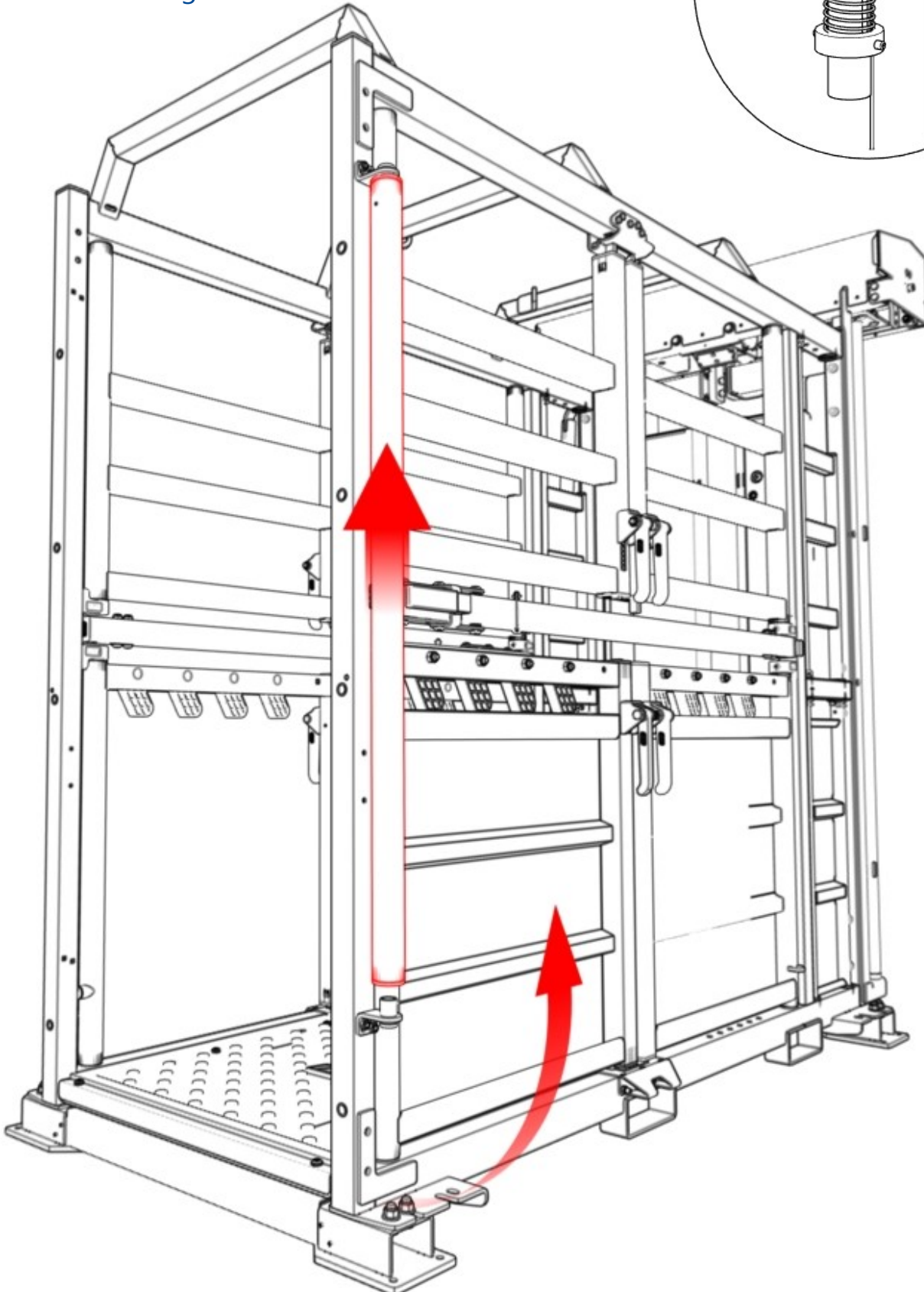
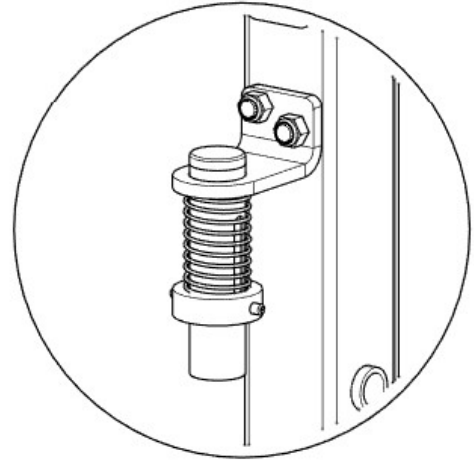

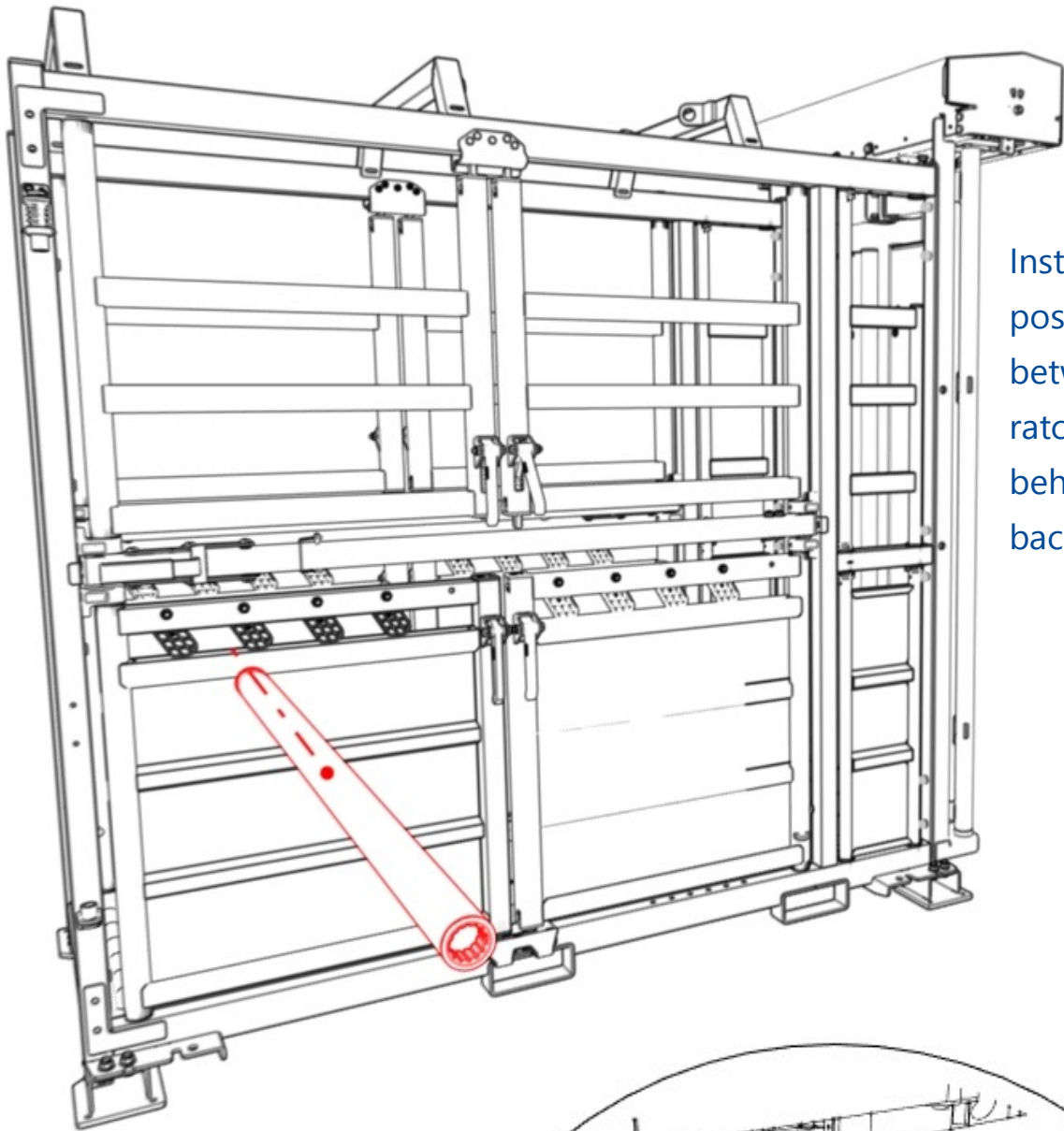

Instruction:
position rump rail
between the
ratchet system,
behind the animal's
backside!

CAUTION: Animal must
be inside the chute and
yoked before positioning
the rump rail.

Slide up to be **tight**
behind animal's rear.

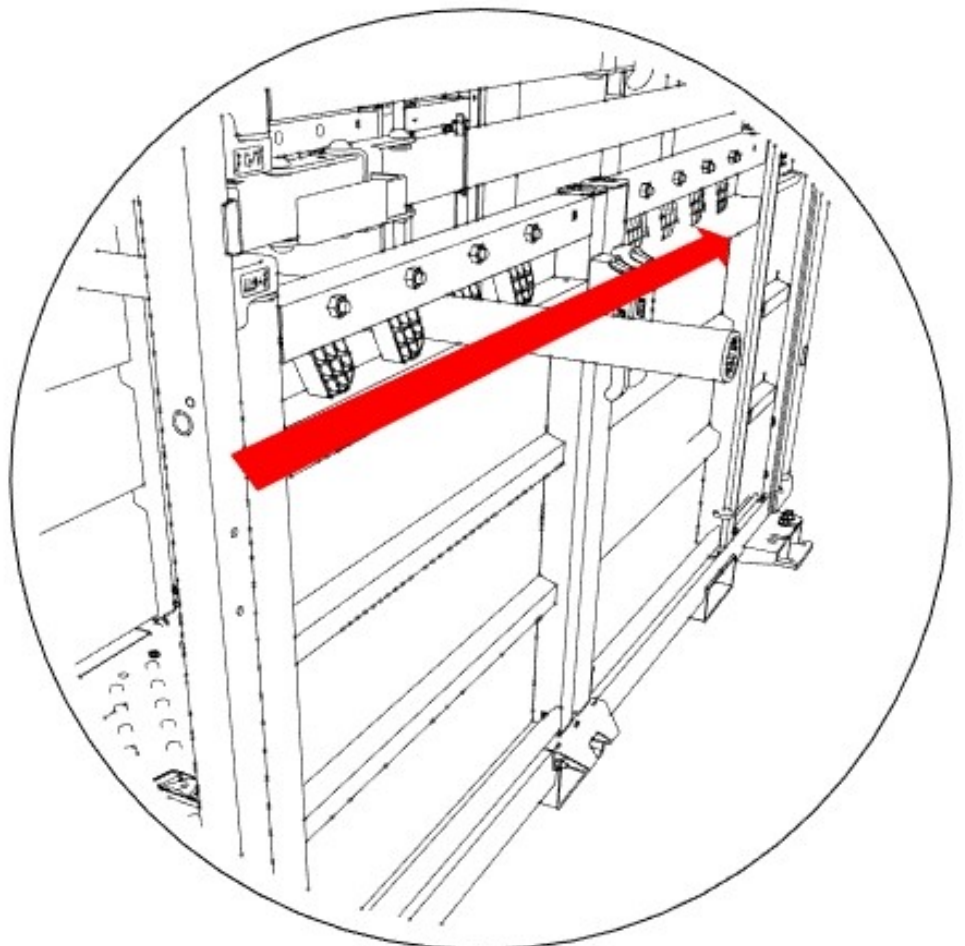

RECOMMENDED MAINTENANCE

REGULAR MAINTENANCE CHECKS TO THE PRODUCT WILL GIVE EARLY WARNING OF ANY PROBLEMS, SUCH AS DAMAGE, CORROSION OR MISSING PARTS AND WILL ENSURE YOUR PRODUCT IS RUNNING SMOOTHLY AND SAFELY.

- ❑ General inspection of the entire product.
- ❑ Check operation of all spring-loaded latches associated with the side doors. Ensure all moving components are free of debris and are functioning correctly.
- ❑ Any damage to steelwork (causing exposure of bare metal) should be made good by rubbing down and applying x1 coat of galvanizing coating and x1 of oil based paint.
- ❑ Check all fasteners sets are tight. Ensure all parts are in place before each use.
- ❑ Remove any obstructions and cut away any vegetation growing on the kit.
- ❑ Lubricate all moving parts, in particular latches and locking systems
- ❑ Simply cleaning down after each use will increase the working life due to the highly corrosive effect of animals urine and/or faeces.

CONTACT

IAE HEADQUARTERS
Mossfield Road
Adderley Green
Stoke-on-Trent
England
ST3 5BW

T: +44 (0)1782 339320

F: +44 (0)1782 339321

E: sales@iae.co.uk

Company Reg number: 01448116 Company VAT number: 319060967

TECHNICAL DOCUMENT NO. 1003598-01