



<https://iae.co.uk/>

AG-fit Waterers

Installation, Operation & Maintenance Manual

D000007-02

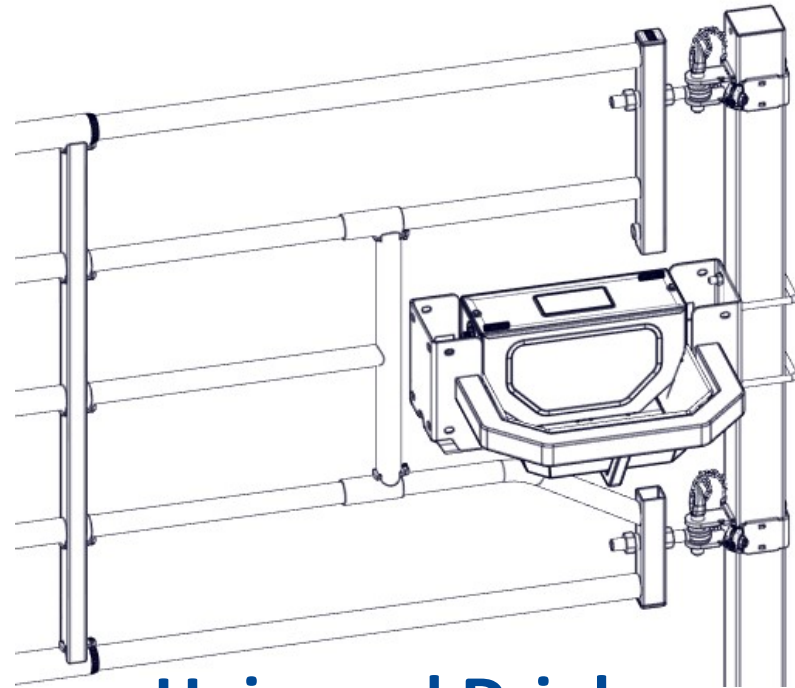

Universal Drinkers



VisorDrink®



the solution that fits

Contents

Health & Safety	4
Universal Drinkers	5
Drinker Insert Variants.....	5
Combining Drinker Insert Variants.....	6
Bracket Positions & Post Configurations.....	7-8
Universal Drinker Mounting Options.....	9
Water Supply Installation.....	10
VisorDrink®	11
Mounting Options.....	11-12
Setup Between Posts Guide.....	13
Bracket Positions & Post Configurations.....	14
VisorDrink® Trough Assembly.....	15
VisorDrink® Items To Be Assembled Parts List.....	16
Water Supply Installation.....	17-22
Maintenance & Storage	23

Health & Safety

PLEASE TAKE NOTE OF THE FOLLOWING SAFETY PRECAUTIONS BEFORE USE FOR THE WELLBEING OF ALL ANIMALS AND PERSONNEL. ANY HARM OR INJURY WHICH OCCURS FROM THE LACK OF COMPLIANCE WITH THESE HEALTH AND SAFETY MEASURES WILL BE THE RESPONSIBILITY OF THE OPERATOR.

- **IMPORTANT** Read these instructions carefully before use and keep them for future reference. The safety of your animals may be affected if you do not follow these instructions.
- Personal protection may be required for some stages of installation.
-  **CAUTION** When handling heavy equipment, some stages of installation may require at least two people.
- **DO NOT** lean on or exert undue pressure on partially assembled or loose equipment.
-  **CAUTION, CHECK POSTURE** when lifting/moving the equipment
- **ALWAYS** Check all parts are present before use.

If you have any questions or comments regarding *AG-fit*, we will be glad to hear them either through our website www.iae.co.uk or by contacting your local IAE dealership.



Universal Drinkers

Drinker Insert Variants

Both single and double sided units can be used between pens in a shared arrangement, mounted independently or using IAE universal brackets and 'U' bolts to fasten onto post - see section 'Universal Drinker Mounting Options' on page 9 for more details

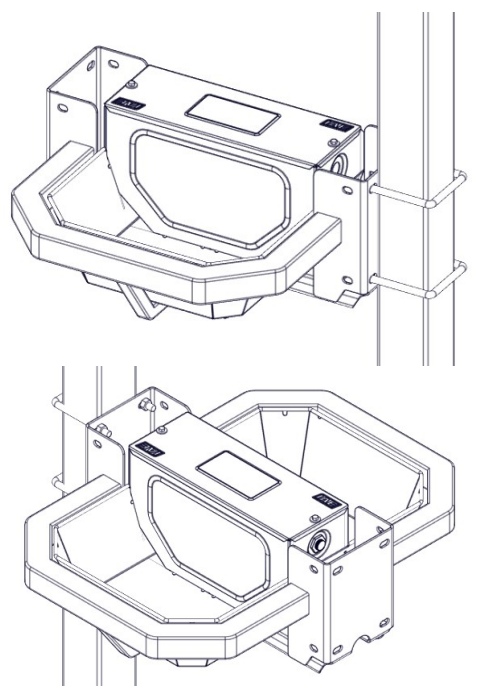

AG-fit drinker inserts joined and combined with primary insert are used to make **3 different options for mounting universal drinker onto posts** (at heights to suit variable animal sizes and also the intended use of the drinker), these include setups suitable for,

Option 1 - 850mm height from ground to lip of drinker, with little adjustment

Option 2 - Ranges from 780mm to 940mm height from ground to lip of drinker, allowing greater clearance for adjustment

Option 3 - 1025mm of clearance available (dimension from ground to underside of end panel 2nd rail), to accommodate free standing or low mounted drinkers

⚠ DO NOT use drinker inserts for hanging gates onto post

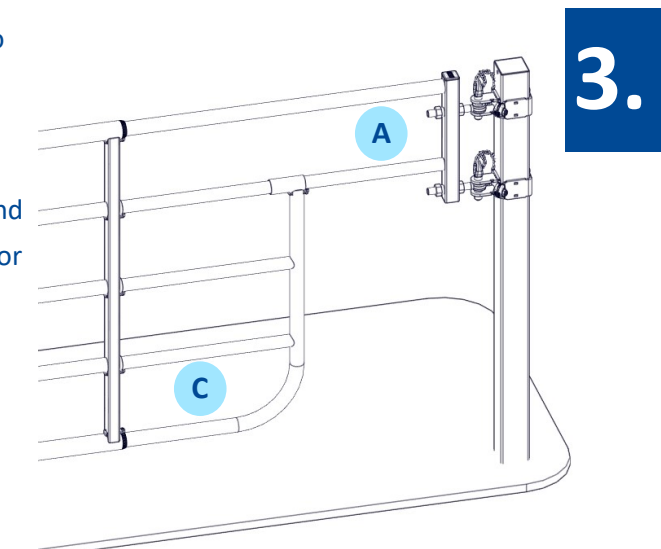
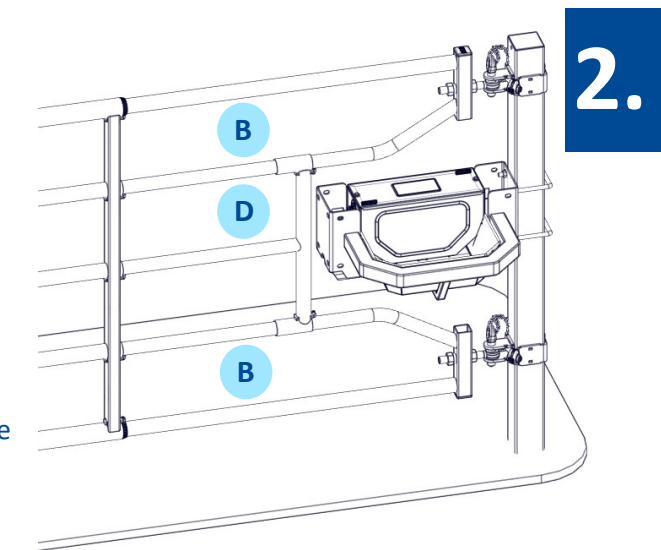
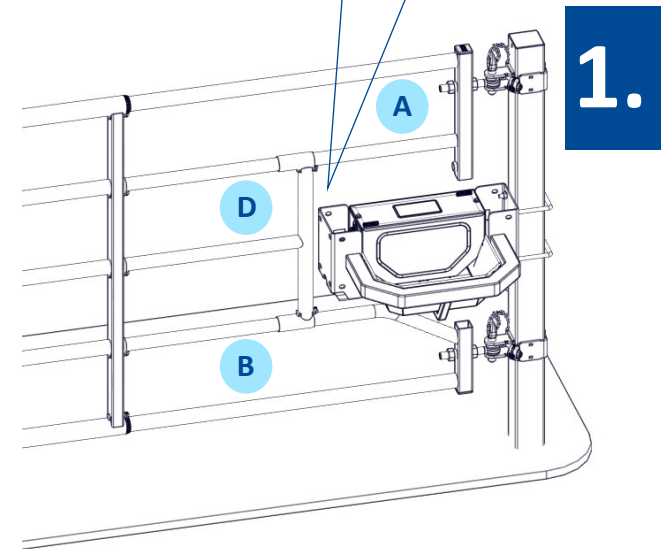
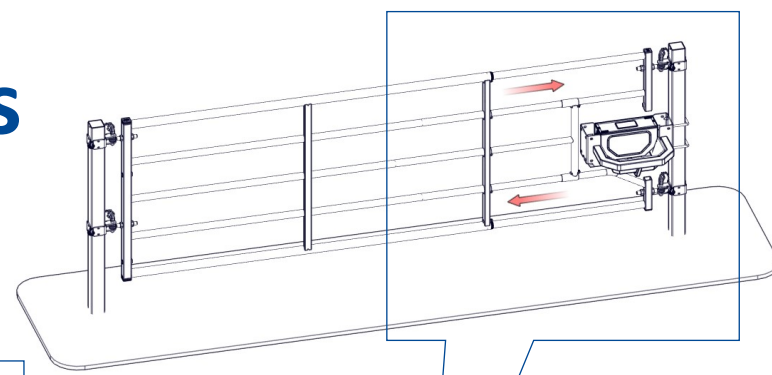

Combining Drinker Insert Variants

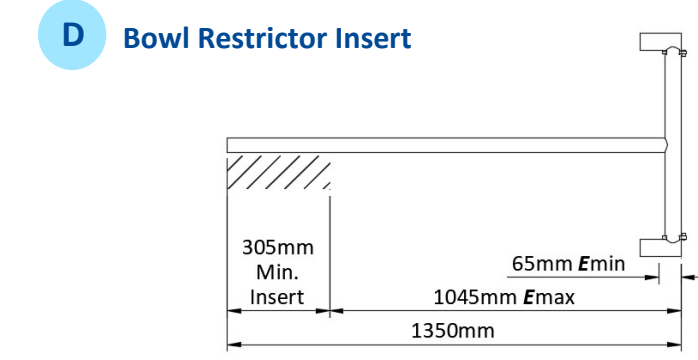
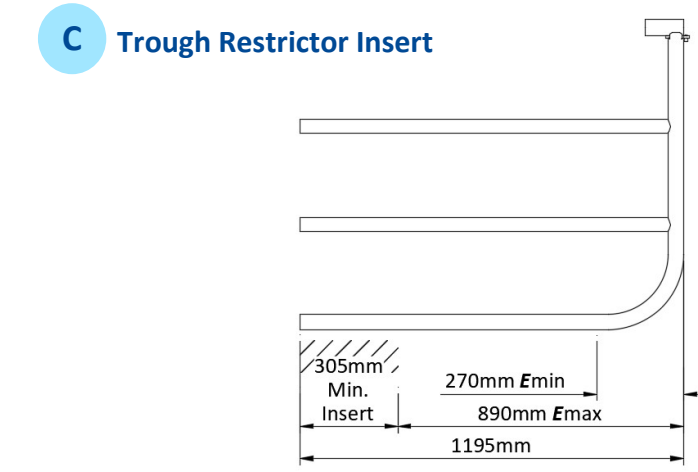
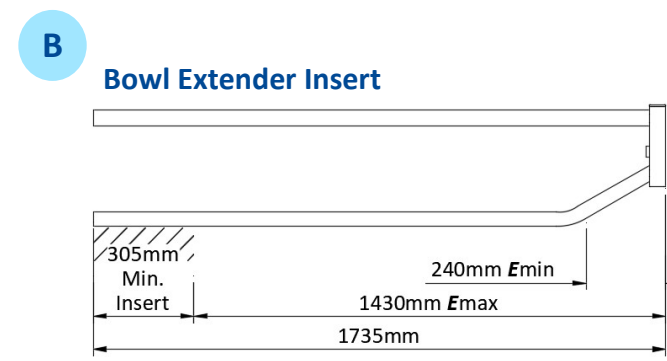
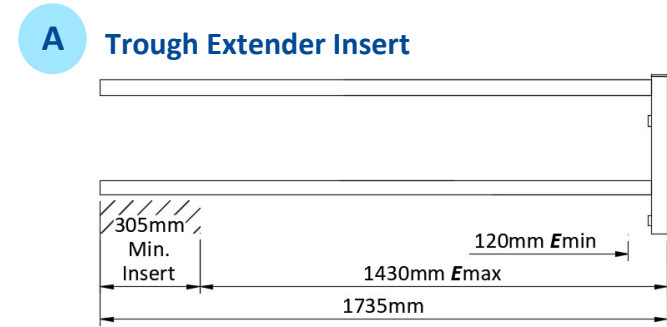

Example Drinker Insert Joining,

- ⚠ Insert requires minimum 305mm insertion into Primary Element
- ⚠ Prioritise the insertion of restrictor type inserts (1) before extender type (2)

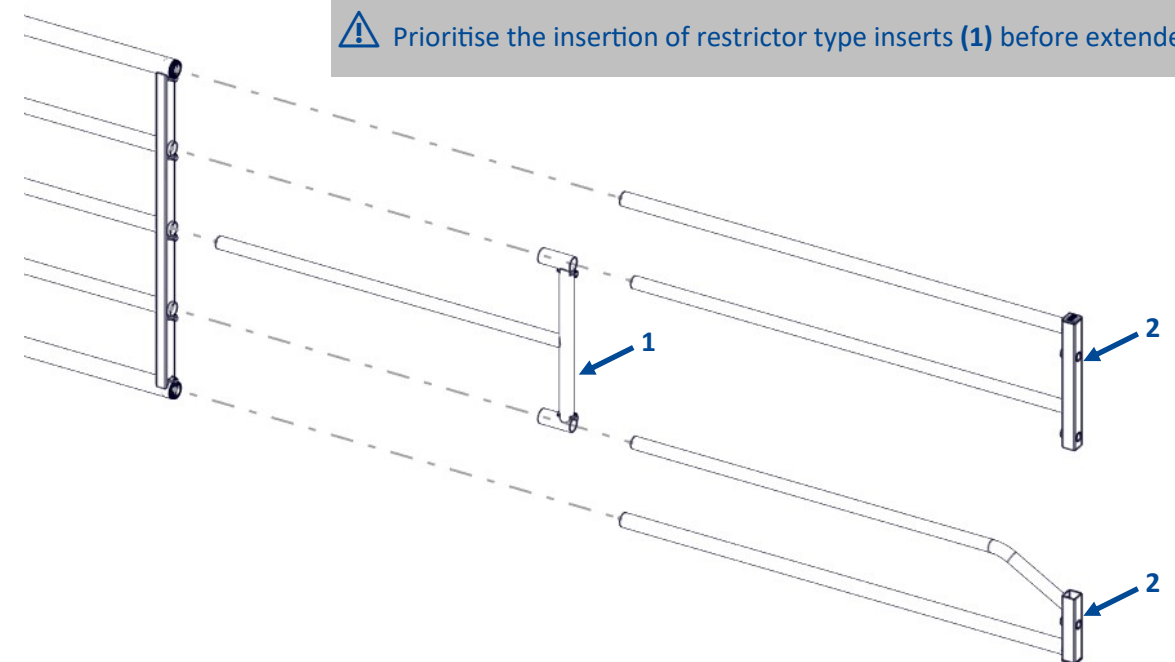

Bracket Positions & Post Configurations

Bracket Positions - Dimensions are from top of post to upper face of brackets

1.

Post Type; To Suit Option 1 Uni Drinker Inserts

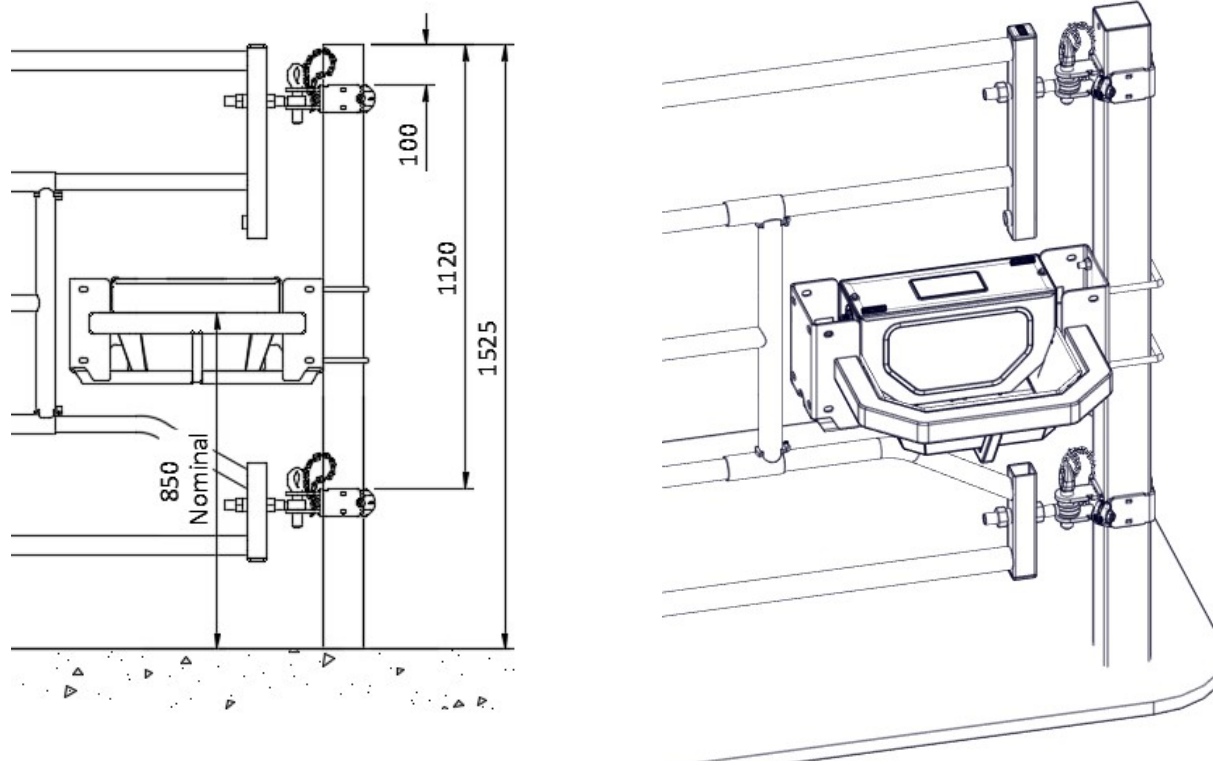

3.

Post Type; To Suit Option 3 Uni Drinker Inserts

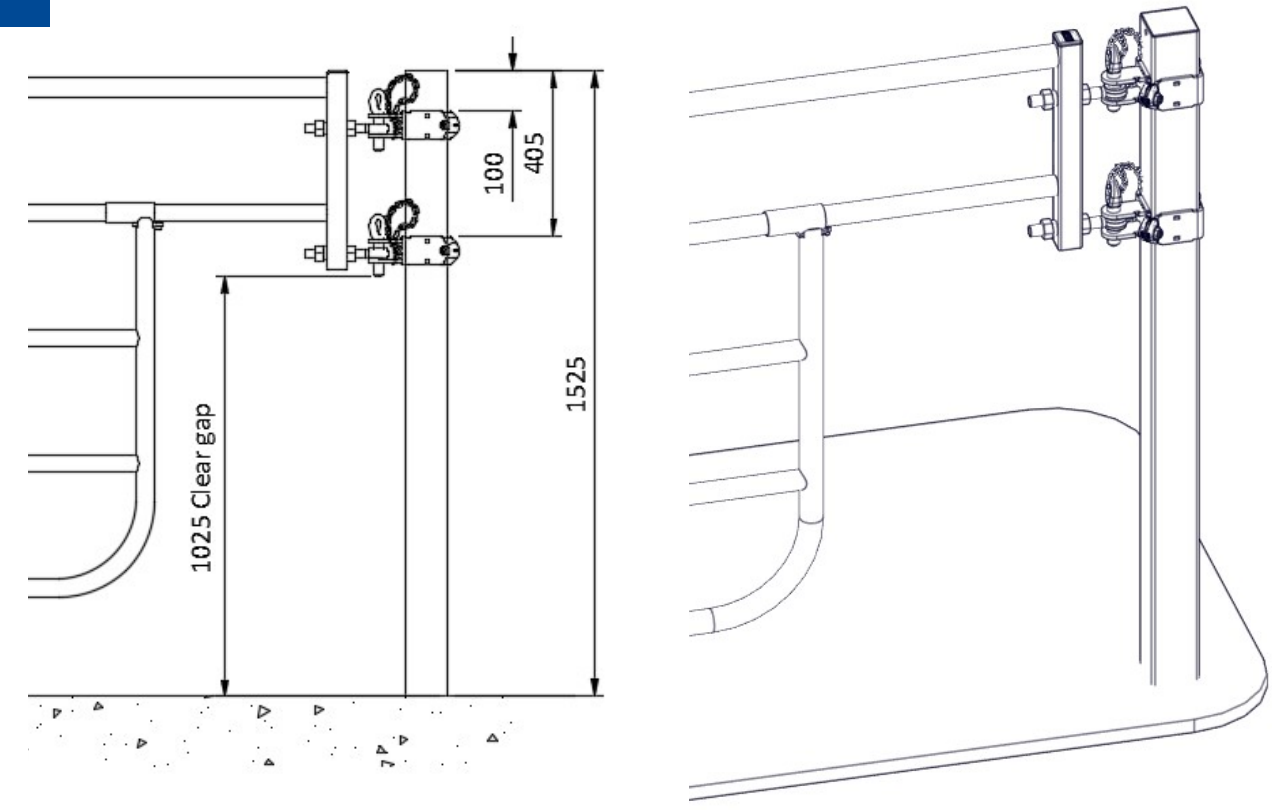

2.

Post Type; To Suit Option 2 Uni Drinker Inserts

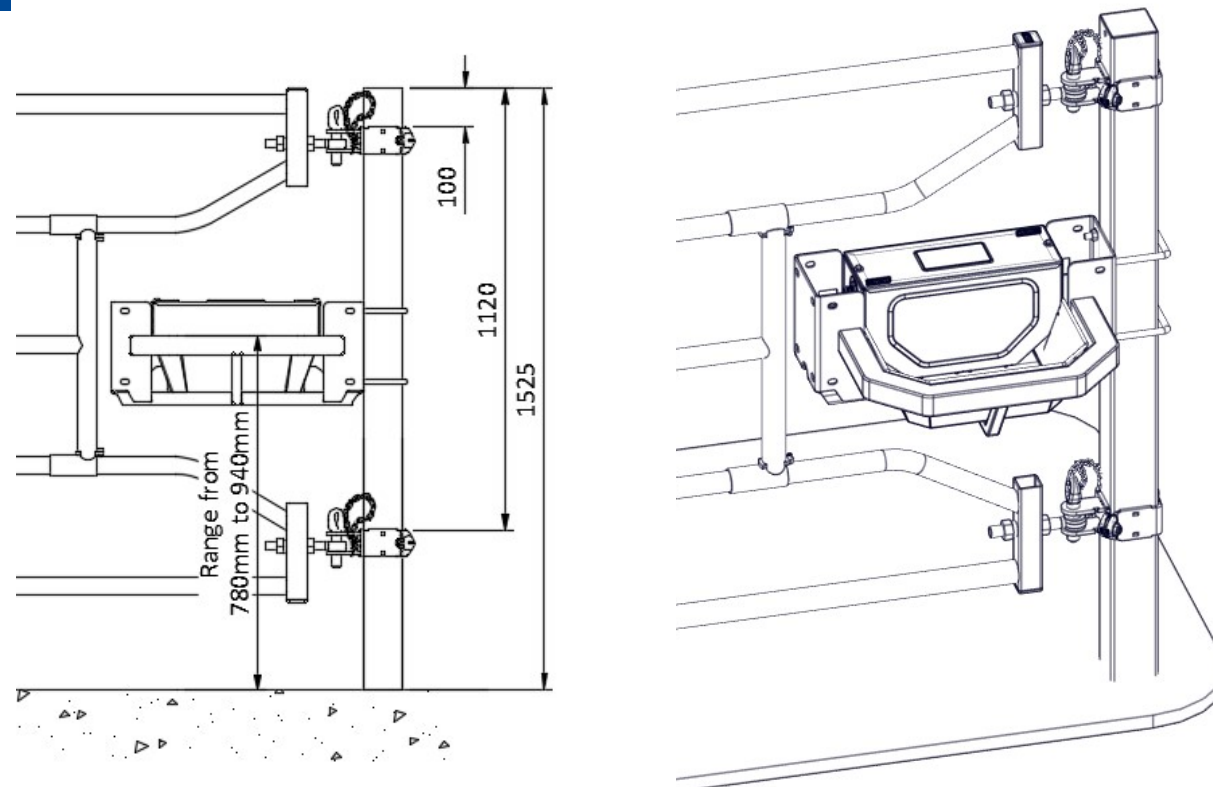

Universal Drinker Mounting Options

WALL

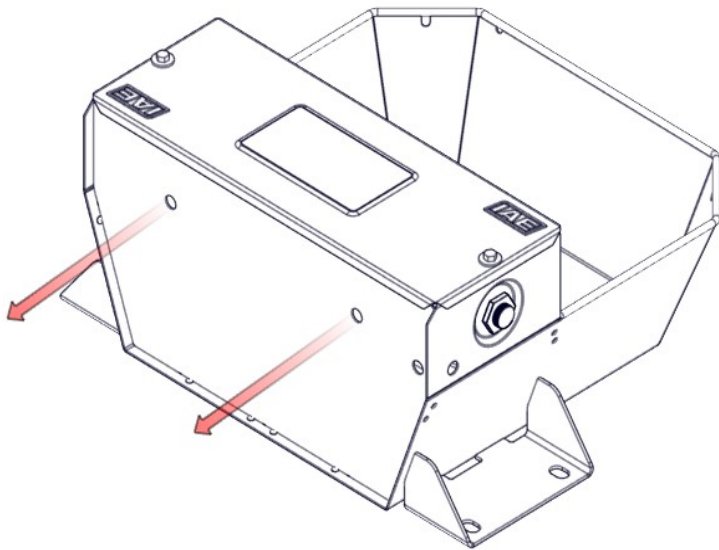

Independently bolted to wall through holes in the service box back face (fittings not supplied)

⚠️ Option to suit single sided universal drinker ONLY

POST

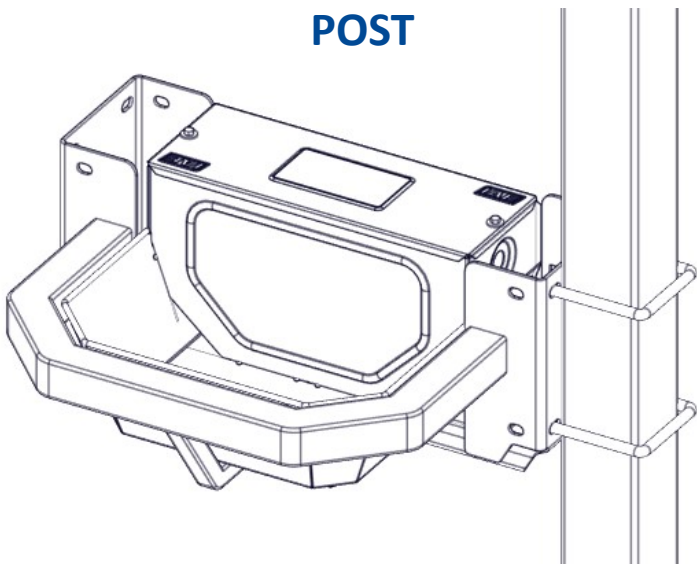

Universal drinkers fastened into IAE universal brackets (attach bracket to corresponding fixing holes in the base plates) use U' bolts to mount onto post

⚠️ 'U' bolts sizes available to suit variable post sizes 100x100 and 120x120

BASE

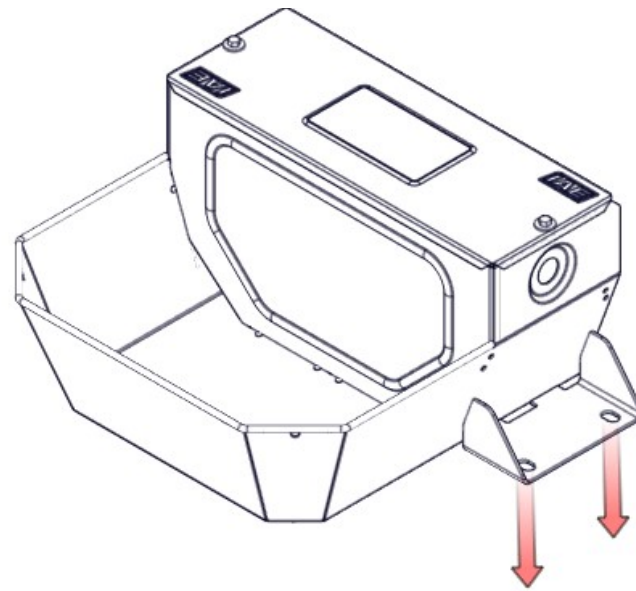

Both single and double universal drinkers can be base mounted through holes in the base plate (x2 fixing holes on either side, also fittings not supplied)

RSJ

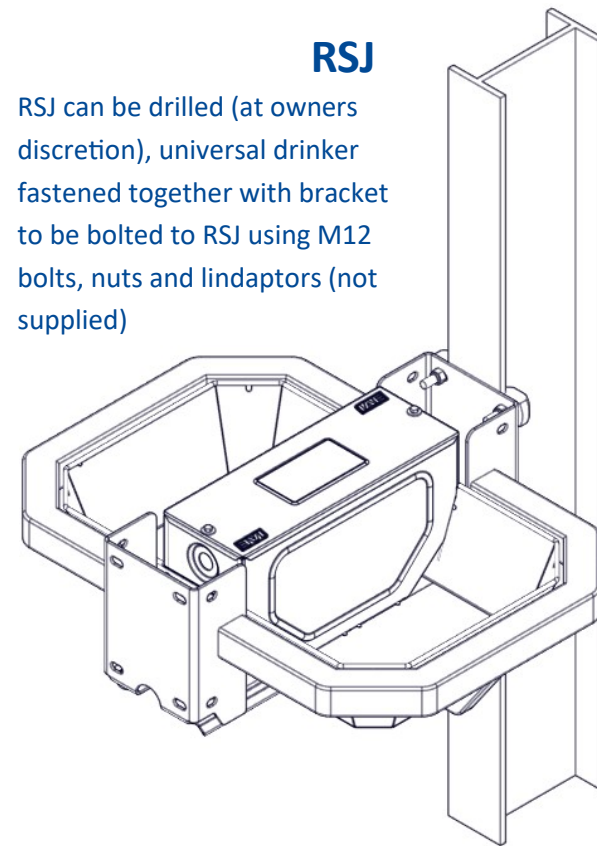

RSJ can be drilled (at owners discretion), universal drinker fastened together with bracket to be bolted to RSJ using M12 bolts, nuts and lindaptors (not supplied)

⚠️ IAE cannot accept responsibility for damage procured through drilling of RSJ - MAX. FLANGE 102mm

Water Supply Installation



1.

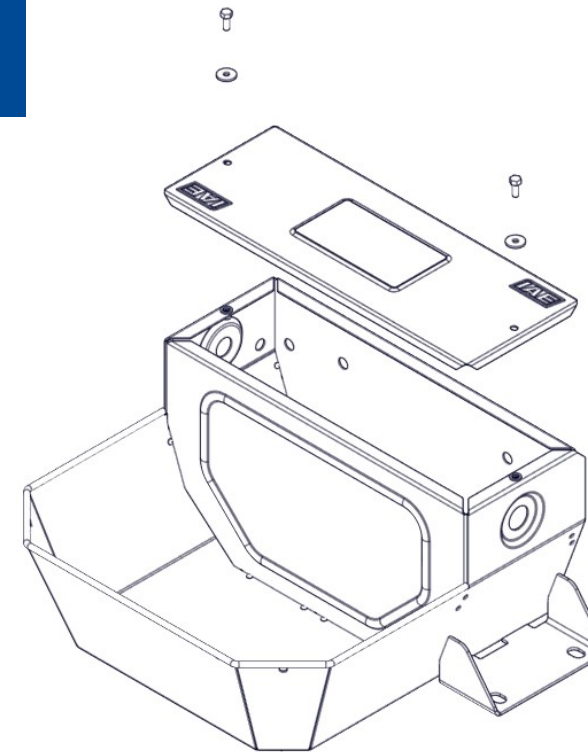

1 - Undo the service box lid (supplied secured) to access the loose components bagged up inside

3.

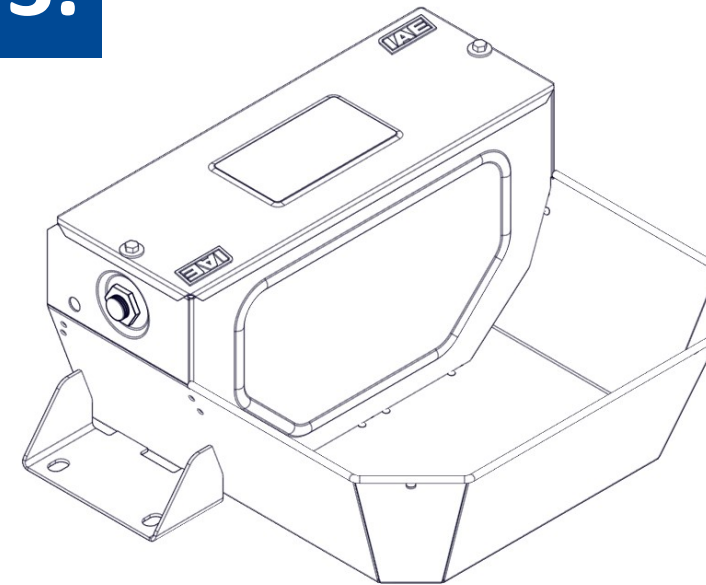

3 - Secure the service box lid

2.

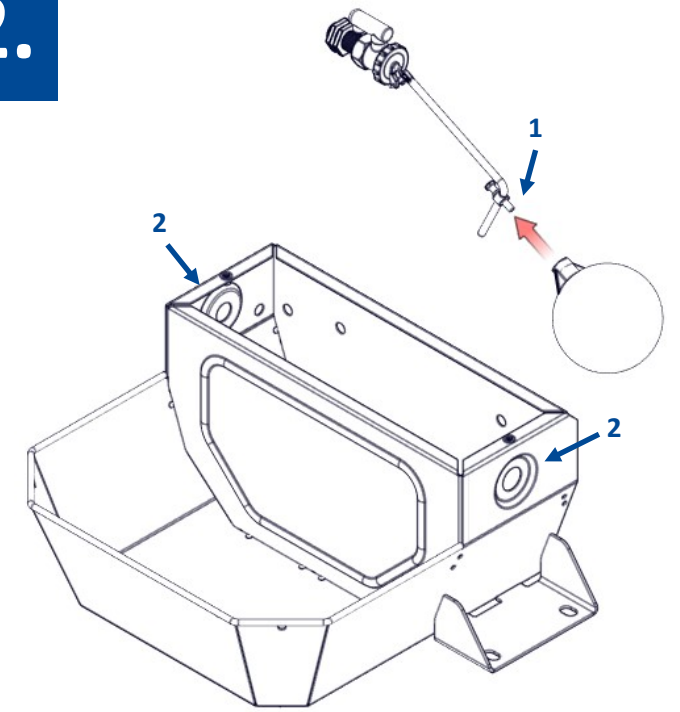

2 - Fit poly float to ball valve (1) Offer up to most suitable Ø27 hole (one on either side), ideally the one closest to water supply route (2)

4.

½ inch 90° threaded elbow plumbing fitting

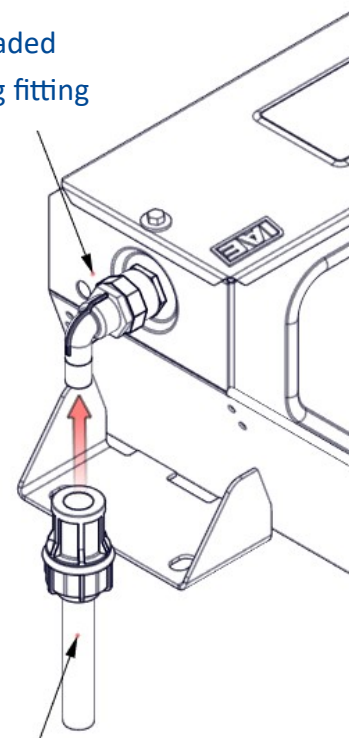

Blue plastic pipe & compression fitting

4 - Connect blue plastic pipe, compression fitting and ½ inch 90° threaded elbow plumbing fitting (parts not supplied)

Mounting Options

Standard Telescopic Brackets

VisorDrink® Standard Telescopic Bracket Kit
Parts List,

1. 2x Standard Top Bracket
2. 2x Standard Bottom Bracket
3. 4x Clamp Bracket Top Plate
4. 4x Clamp Bracket Internal Plate
5. 4x M10 Nyloc Nut

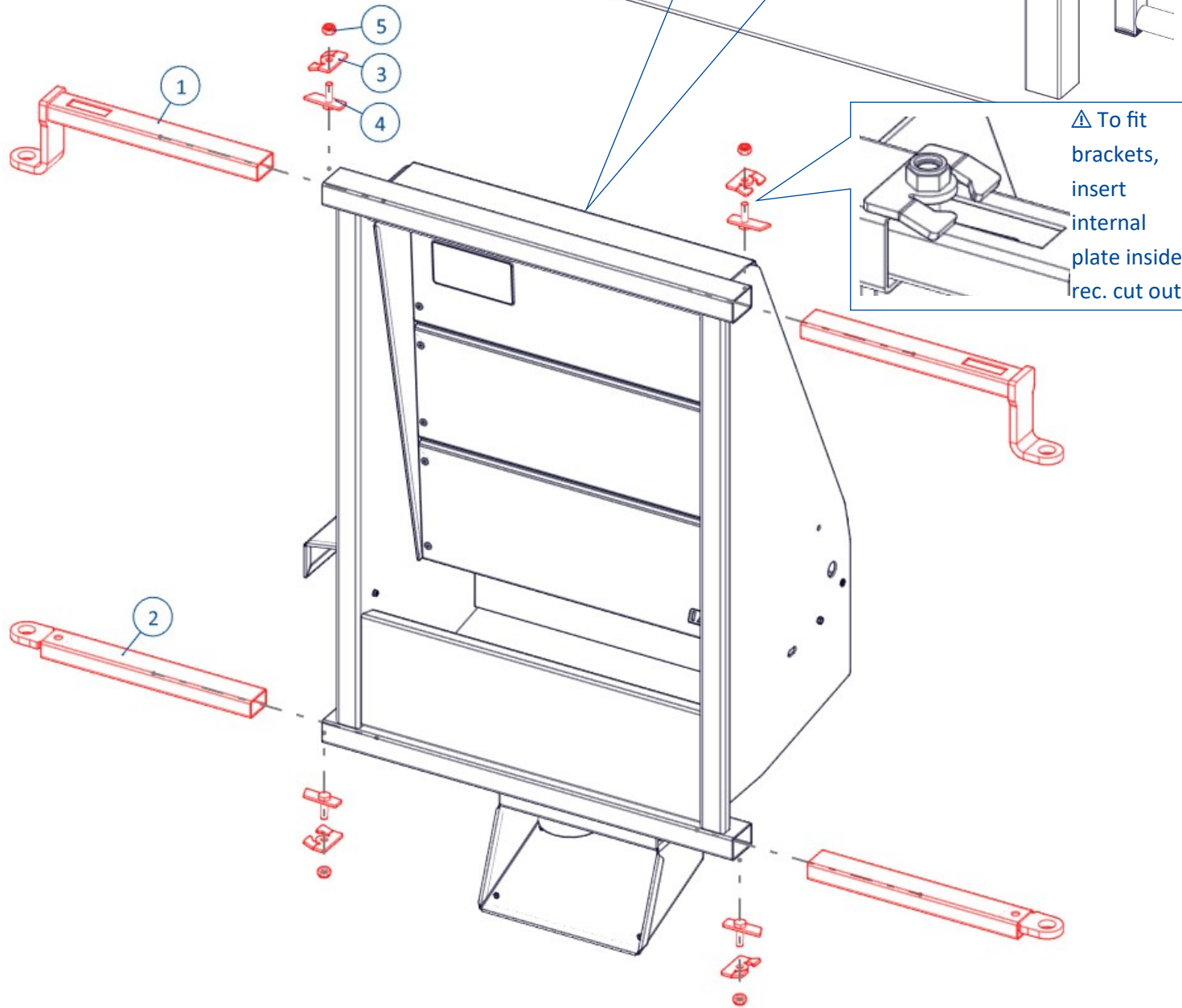

⚠ Telescopic brackets are mounted to post utilising AG-fit hang brackets and coupling rod (one on either side) to hinge VisorDrink® telescopic brackets, opposed to hinge pins used to hang gates or panels (as head-trap prevention)

Extended Telescopic Brackets

VisorDrink® Extended Telescopic Bracket Kit
Parts List,

1. 1x Standard Top Bracket
2. 1x Standard Bottom Bracket
3. 2x Clamp Bracket Top Plate
4. 2x Clamp Bracket Internal Plate
5. 8x M10 Nyloc Nut
6. 1x Extended Top Bracket
7. 1x Extended Bottom Bracket
8. 3x Bolt On Vertical Infiller
9. 6x M10x75 bolt
10. 12x M10 Washer

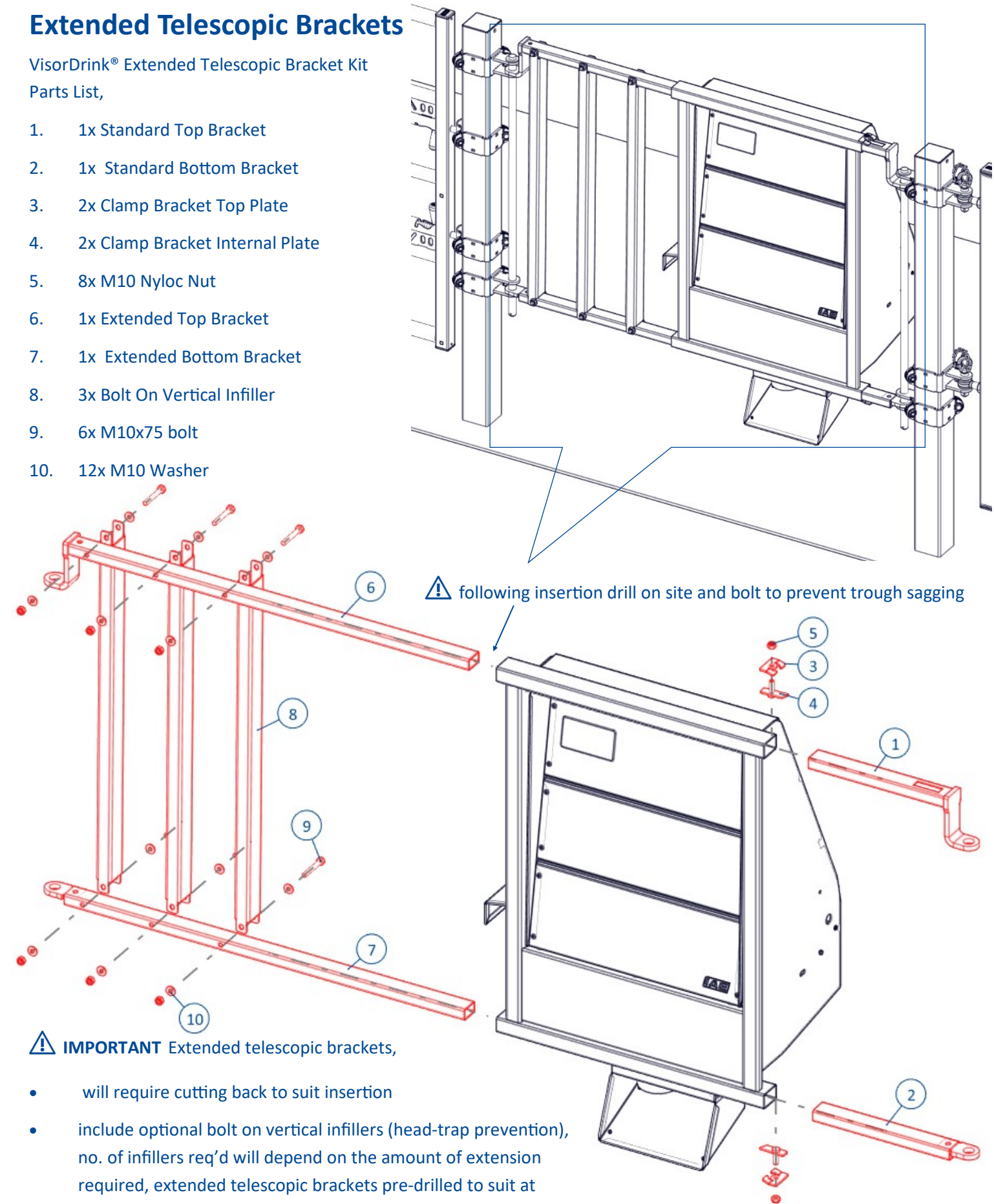

⚠ **IMPORTANT** Extended telescopic brackets,

- will require cutting back to suit insertion
- include optional bolt on vertical infillers (head-trap prevention), no. of infillers req'd will depend on the amount of extension required, extended telescopic brackets pre-drilled to suit at 190mm increments with max. extension utilising 3 vertical infillers

- standard top and bottom bracket positioned closest to water supply route

Setup Between Posts Guide

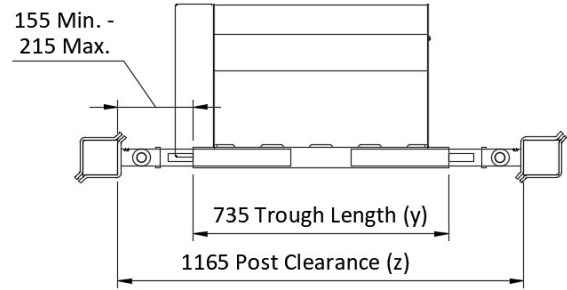
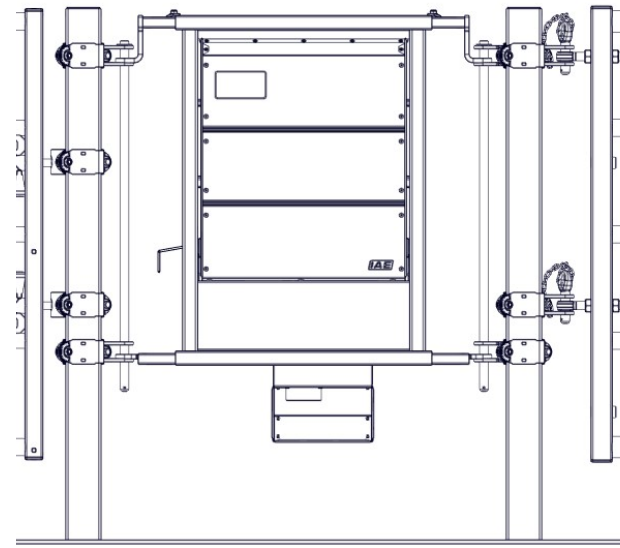

**Example VisorDrink® Setup
Standard Telescopic Brackets,**

Trough Length (y)	Post Clearance (z)
735	1045 - 1165
1345	1655 - 1775
1955	2265 - 2385

Bracket Positions & Post Configurations

- Post Type;**
- Slam/Telescopic Brackets (NO RISE)**
 - Telescopic Brackets/Hang (NO RISE)**

Note: Compatible with bracket positions to suit inserts with fixed hinges

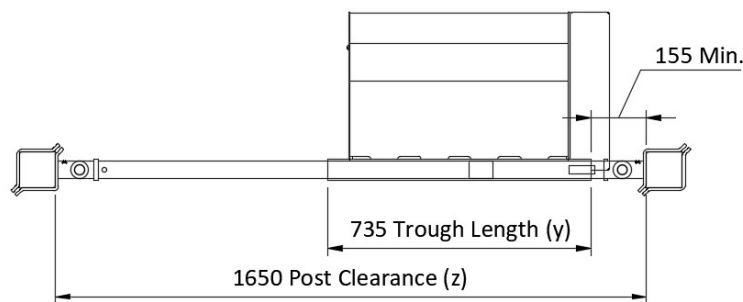
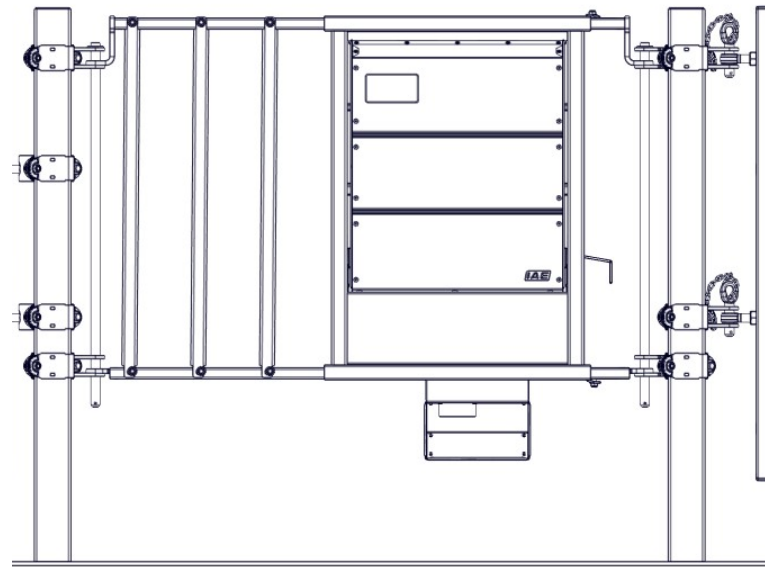
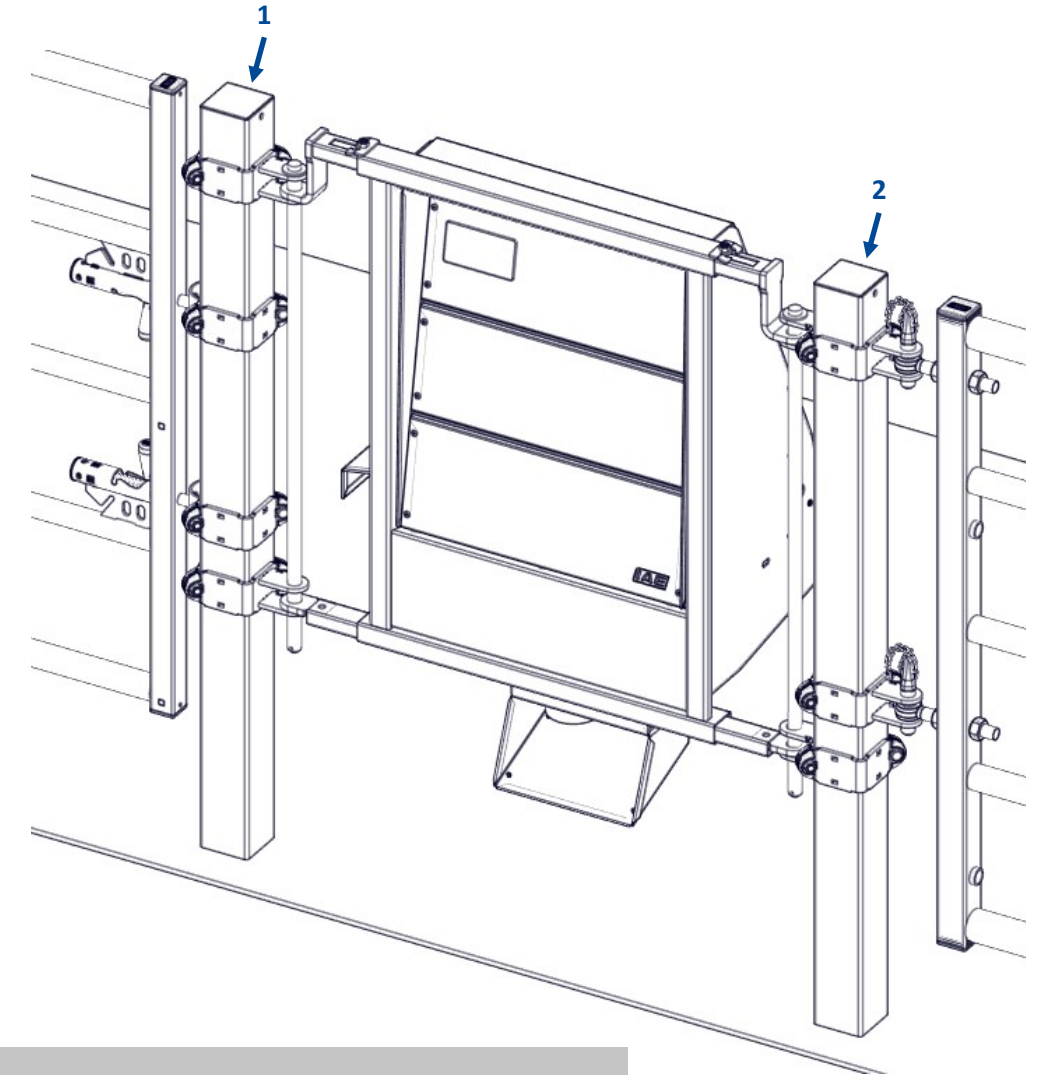

**Example VisorDrink® Setup
Extended Telescopic Brackets,**

Trough Length (y)	Post Clearance (z)
735	1170 - 1650
1345	1780 - 2260
1955	2390 - 2870

⚠ Bracket positions are exactly alike on setups using extended telescopic brackets
Bracket Positions - Dimensions are from top of post to upper face of brackets

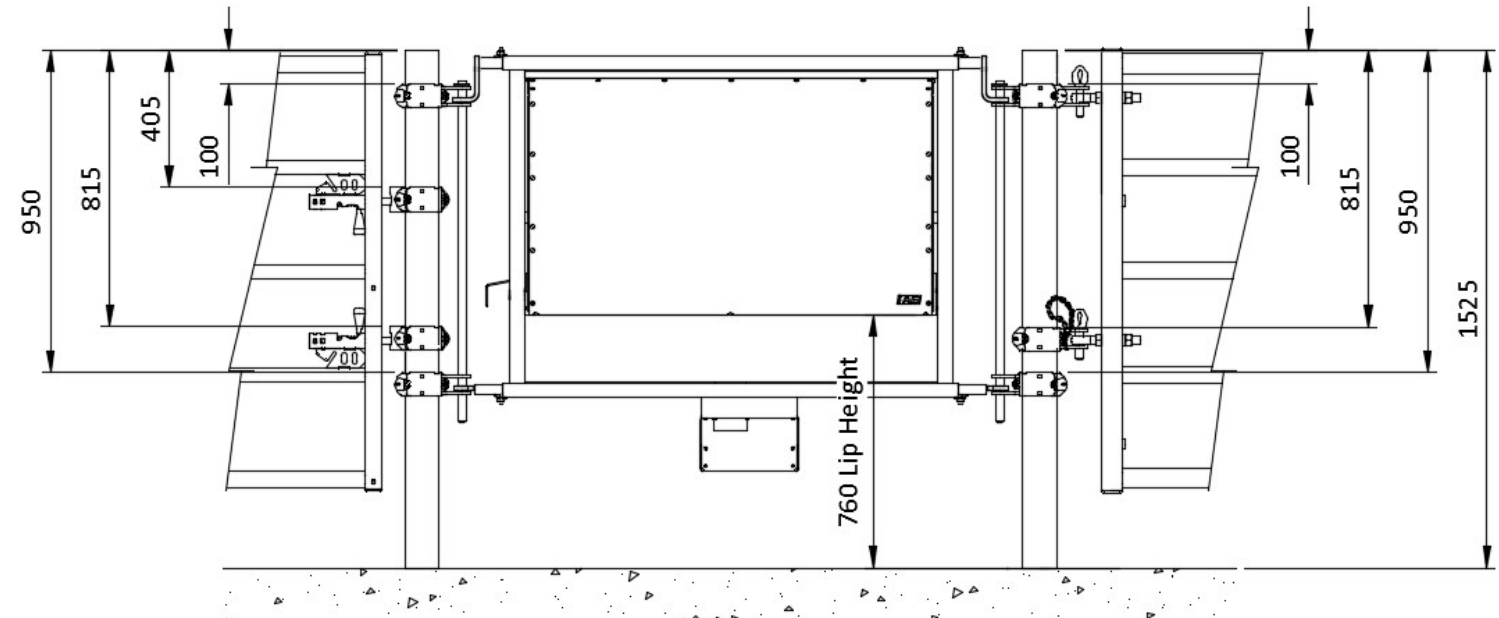

VisorDrink® Trough Assembly

VisorDrink® troughs designed for any hand setup, to suit proposed water supply route

⚠ Blanking caps for closing off redundant holes are **NOT PROVIDED**

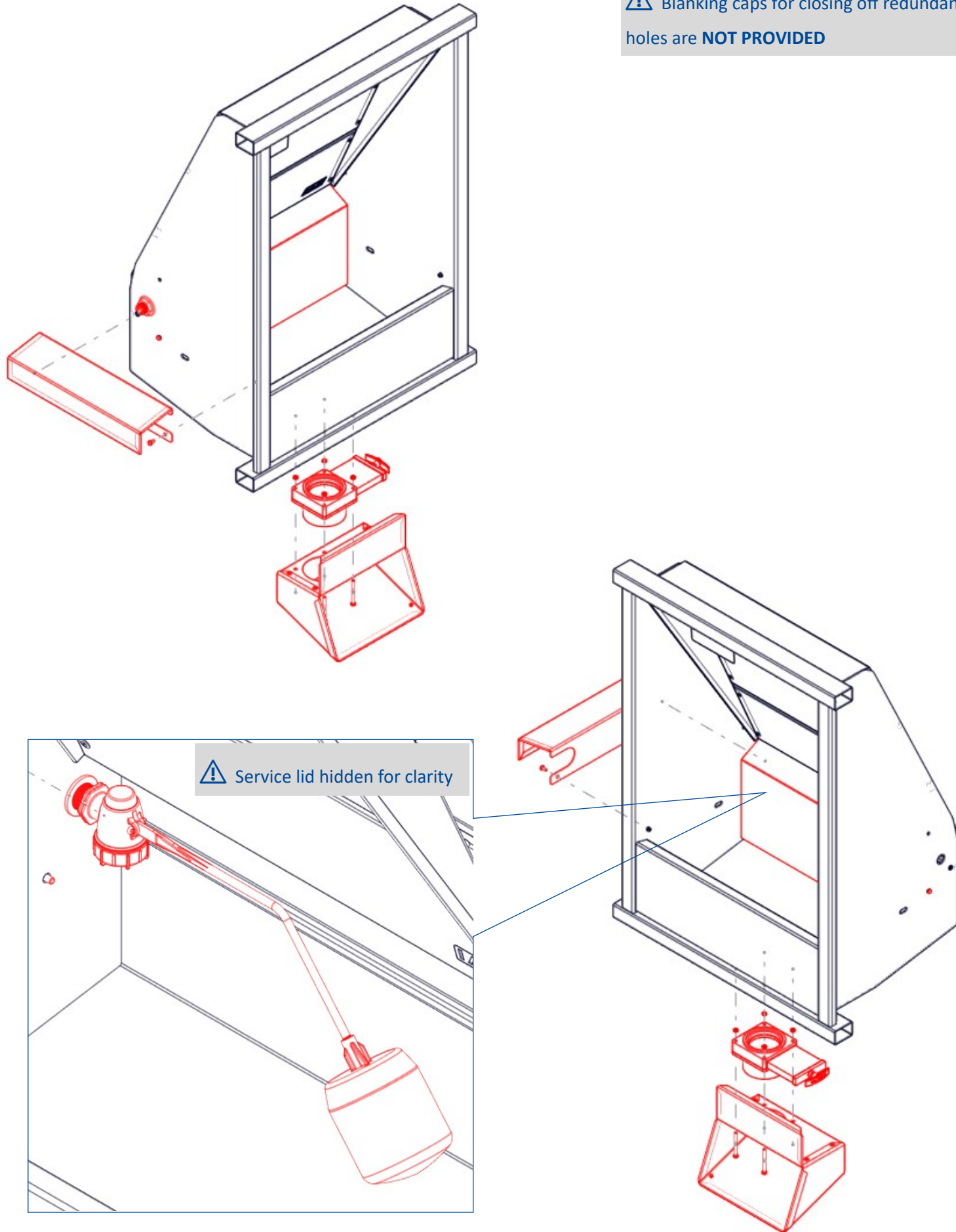

VisorDrink® Items To Be Assembled Parts List

All items shown below to be supplied packed and secured inside trough, follow instructions for how to unpack and setup in section named 'water supply installation' on pages 17 to 22

- | | | | |
|---|-----------------------------------|--------------------------|--------------------|
| 1 | Valterra waste valve 3" | 10 | Service Lid |
| 2 | M6x65mm Bolt | 11 | Waterpipe Shroud |
| 3 | O-ring seal | 12 | Quick Empty Shroud |
| 4 | Flomasta Cylindrical Ball Float | Items 10 to 12 are loose | |
| 5 | Brass Plug | | |
| 6 | M6x10mm Setscrew | | |
| 7 | M6x16mm Setscrew | | |
| 8 | M6 Nyloc Nut | | |
| 9 | RXP Ballcock Valve + straight arm | | |

Items 1 to 9 are contained within VisorDrink® fittings kit No. 1003006

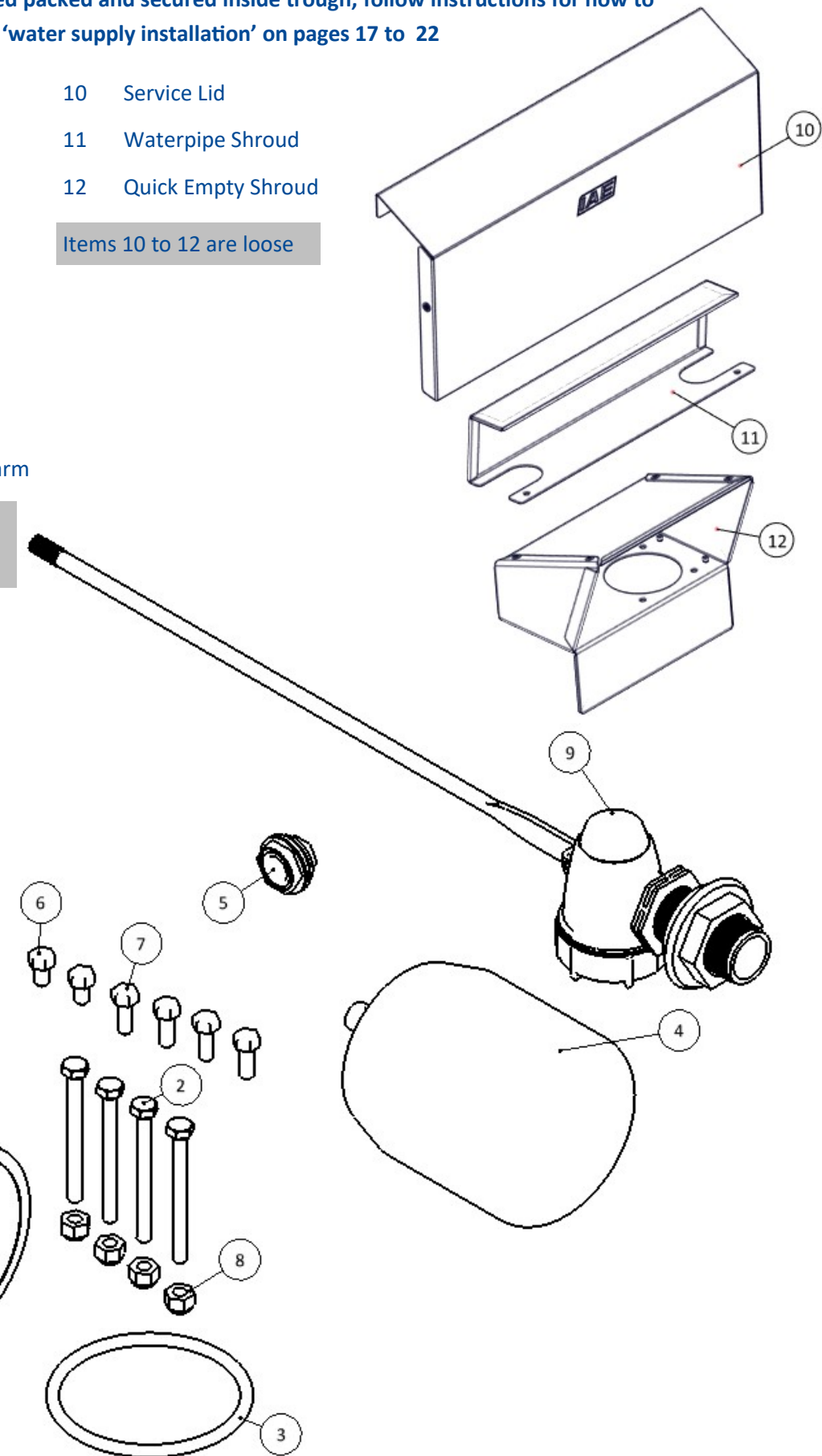

Water Supply Installation

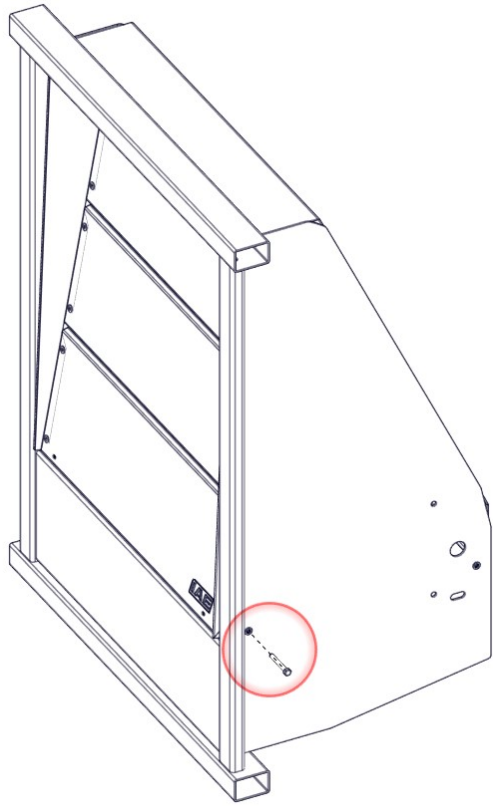

 Ø10mm ring spanner
 Vice
 Set of grips

1.

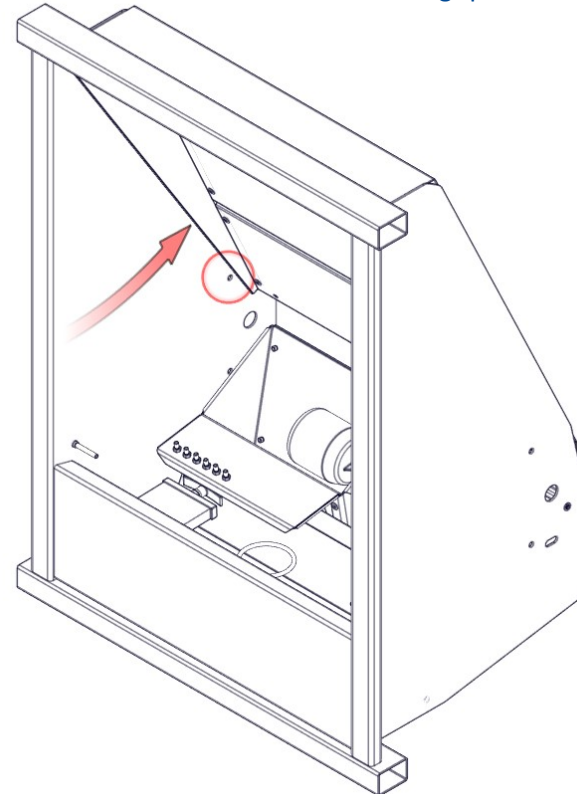

1 - Undo the visor (supplied secured), remove bolt (*highlighted*) to access the items to be assembled inside

2.



2 - Using the same bolt used to secure the visor, reinsert it into the hole (*highlighted*) to hold back the visor whilst installation takes place

3.

IMPORTANT RXP ballcock valve provided with a straight arm which requires bending on site

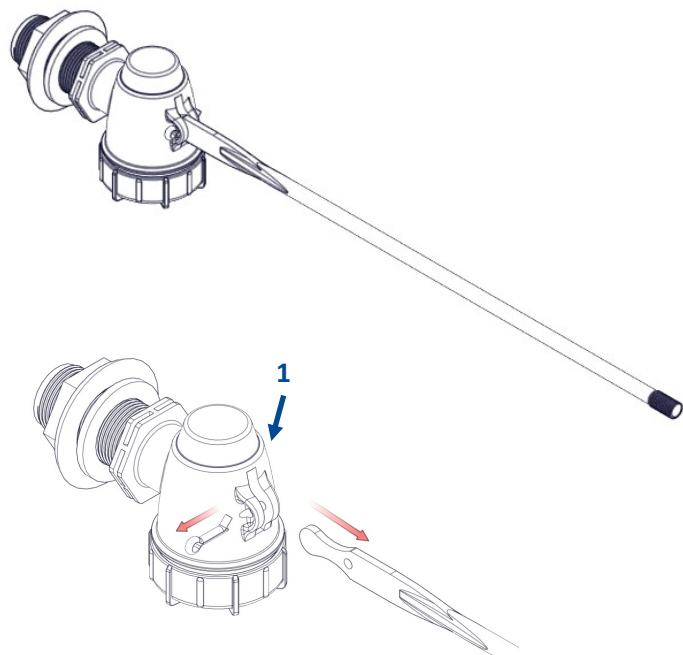

3 - To prepare for bending, remove the pivot pin to separate the straight arm from the ballcock valve (1)

4.



4 - Ideally using a vice and a set of grips, bend the arm 45° and with true alignment, approximately halfway along the complete length of the arm

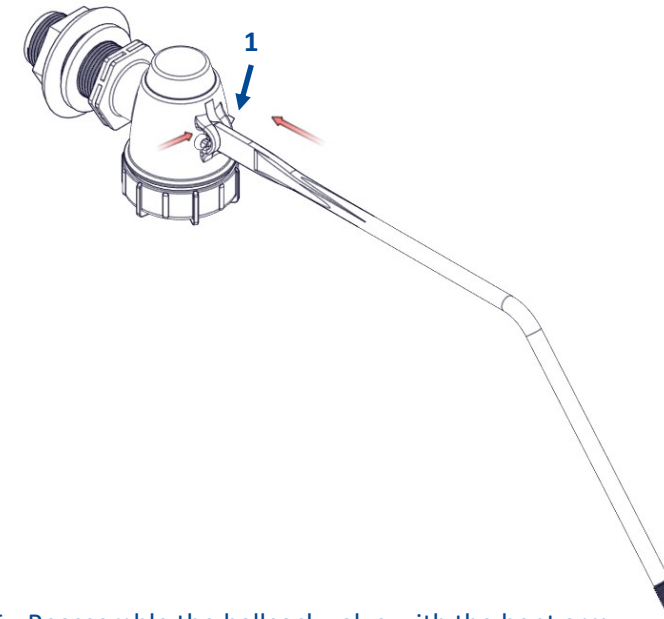

CAUTION plastic threads on the valve are at risk of damage,
 Handle with care | Avoid over tightening | High water pressure may lead to leakages

5.

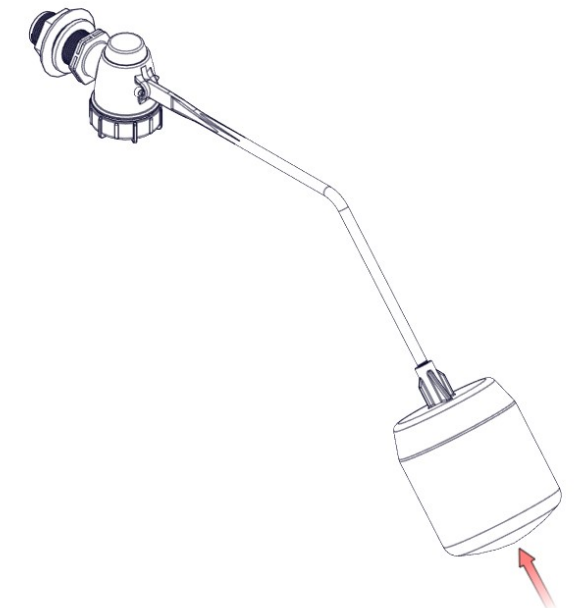

5 - Reassemble the ballcock valve with the bent arm, insert pivot pin (1)

6.



6 - Fit flomasta cylindrical ball float to RXP ballcock valve

Bending Dimensions & Testing Records,

Approx. bend position + angle:

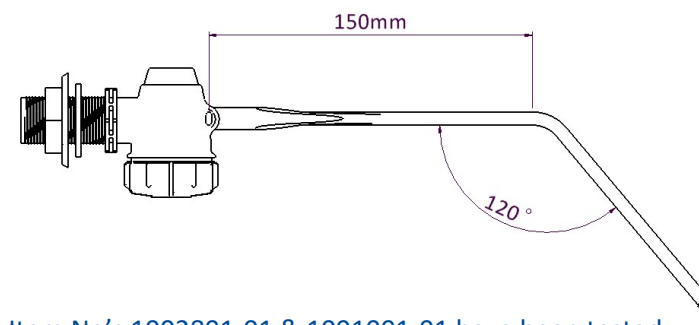

Item No's 1002801-01 & 1001001-01 have been tested up to a maximum of 8 bar, reference image (to right) showing setup at 8 bar pressure

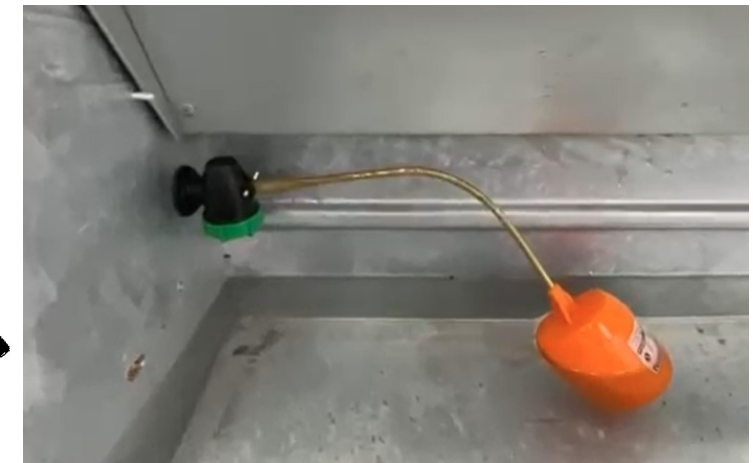

MAINTENANCE Use Teflon tape on threaded connections to prevent leaking (tape not supplied)

Installation continued on pages 19 to 22 >

7.

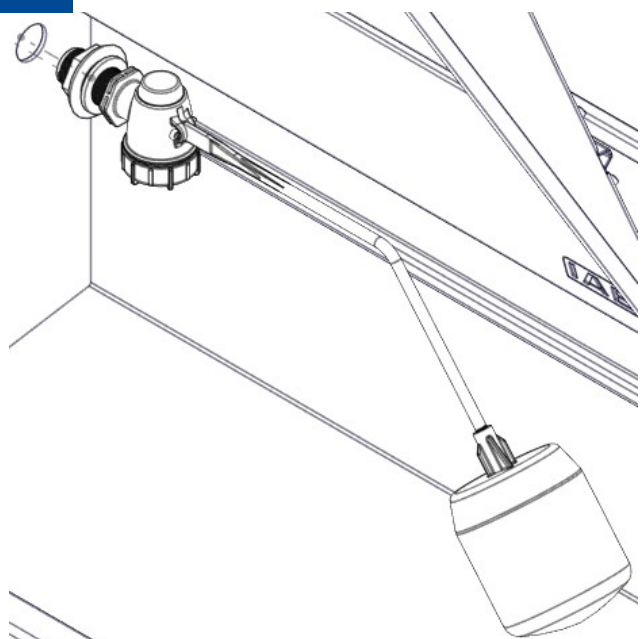

7 - Fit RXP ballcock valve and float inside trough
Offer up to most suitable Ø27 hole (one on either side), ideally the one closest to water supply route

9.

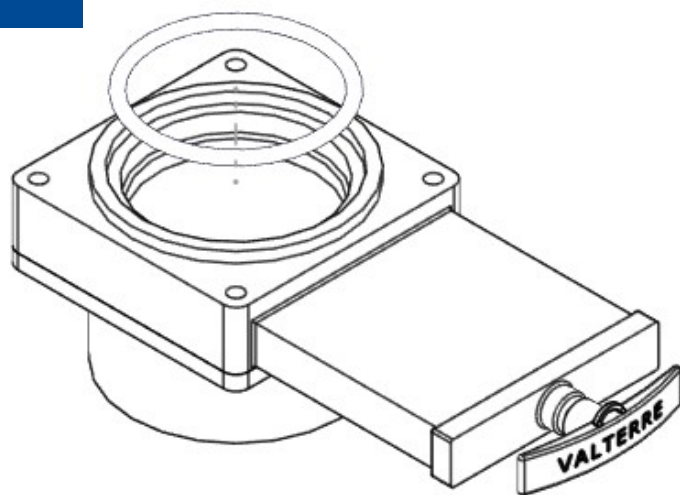

9 - Fit O-ring seal inside the seat recess

⚠ Lubricate O-ring before installation to minimise friction between the sealing ring and the surface it pairing to. Apply a thin film of mineral oil, silicone oil, grease or application fluid

8.

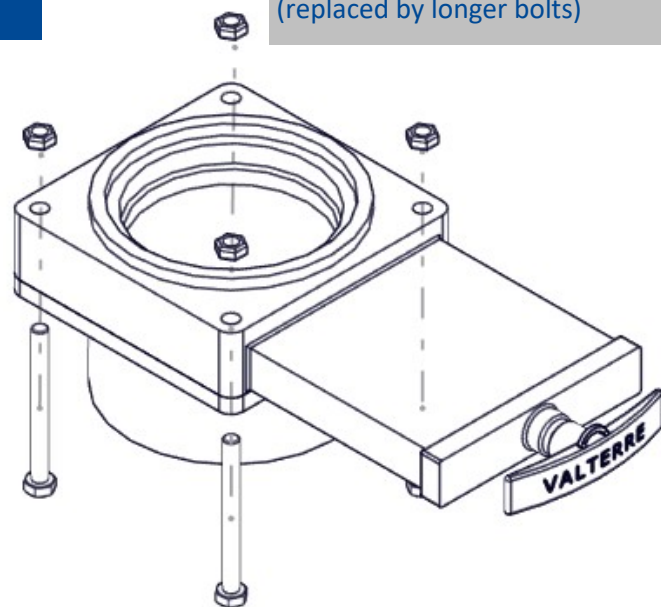

⚠ Discard x4 M6x55mm bolts (replaced by longer bolts)

8 - Remove the bolts and nuts supplied fitted to the Valterra waste valve

10.

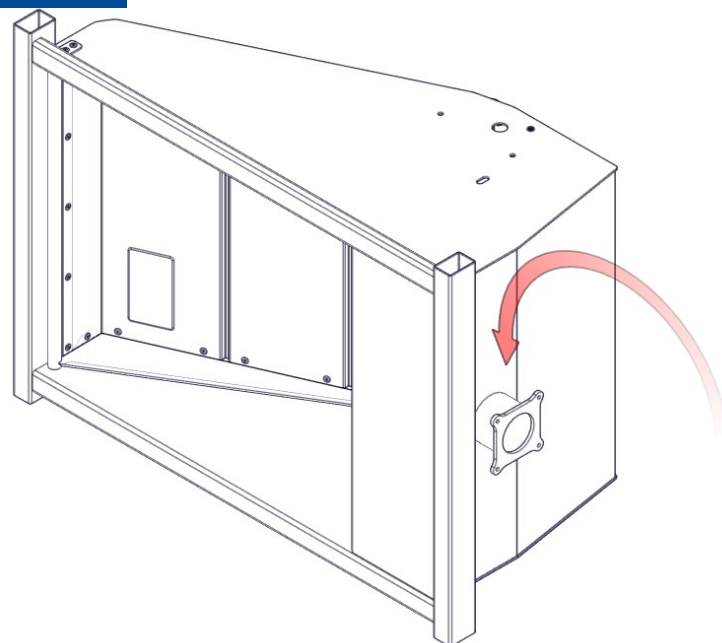

10 - Lay the VisorDrink® trough on it's side to combine the Valterra waste valve and quick empty shroud to the main body

11.

11 - Bolt multiple parts to the tank flange on the underside of the trough in the following sequence,

- x4 M6x70mm bolts (1)
- quick empty shroud (2)
- Valterra waste valve (3)
- x4 M6 full nuts (4)

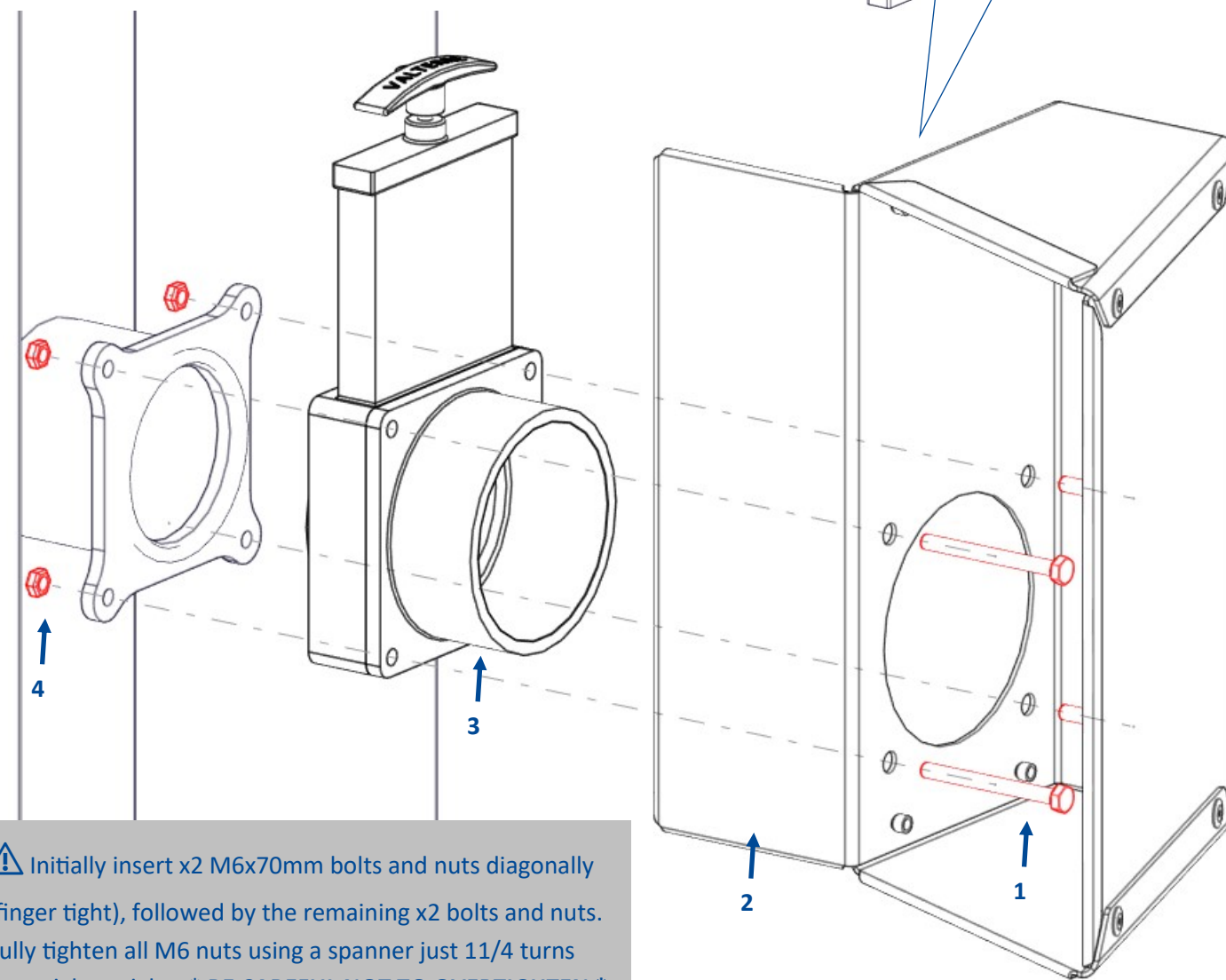
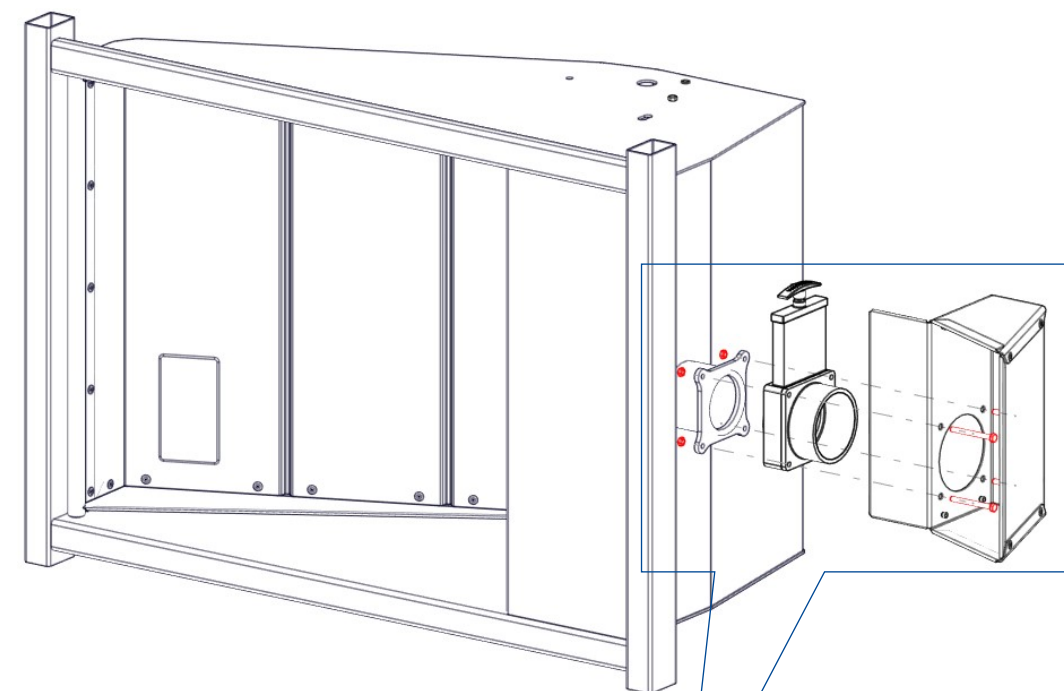

⚠ Initially insert x2 M6x70mm bolts and nuts diagonally (finger tight), followed by the remaining x2 bolts and nuts. Fully tighten all M6 nuts using a spanner just 1 1/4 turns from tighter tight * BE CAREFUL NOT TO OVERTIGHTEN *

12.

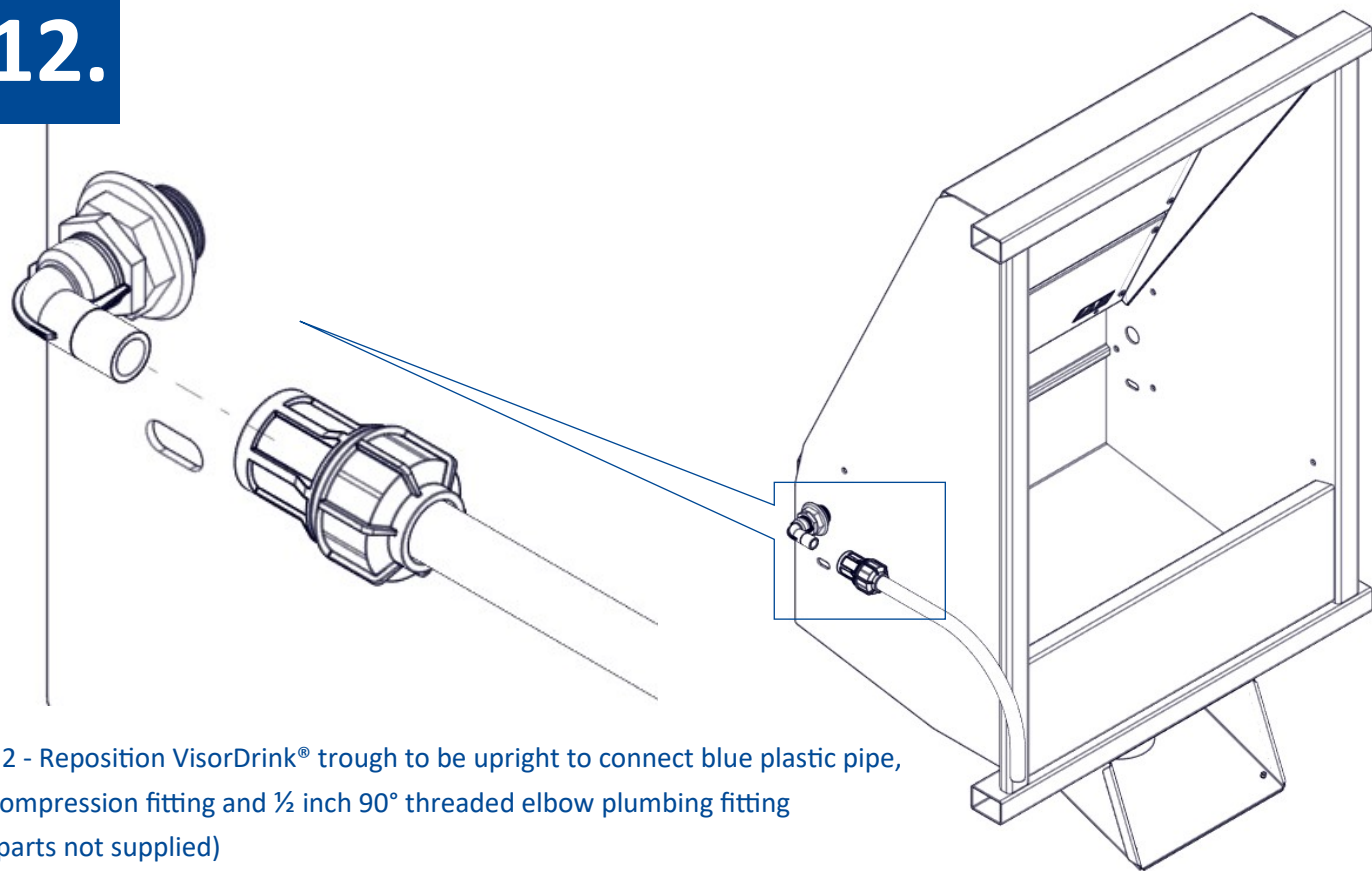

12 - Reposition VisorDrink® trough to be upright to connect blue plastic pipe, compression fitting and ½ inch 90° threaded elbow plumbing fitting (parts not supplied)

13.

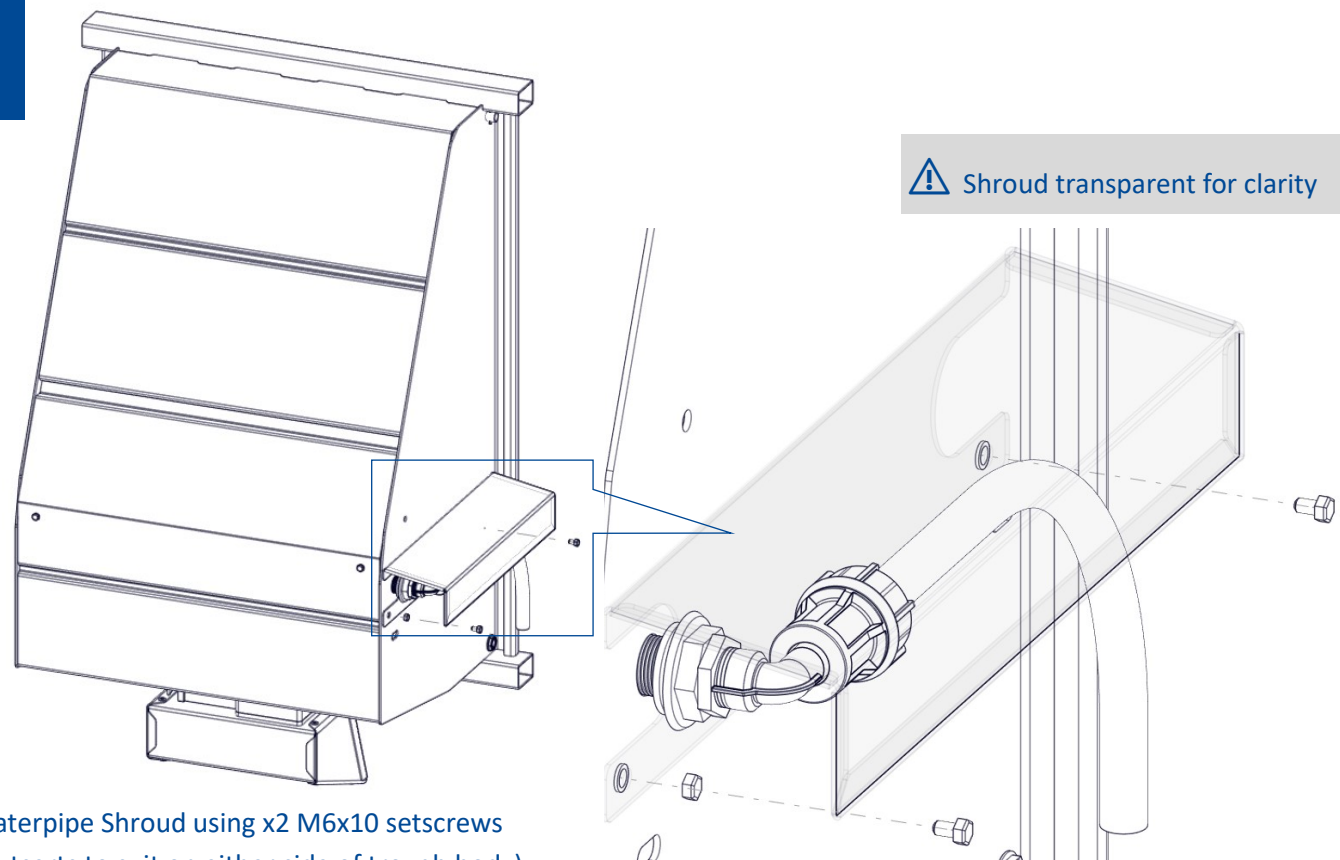

13 - Fit Waterpipe Shroud using x2 M6x10 setscrews (built-in nutserts to suit on either side of trough body)

⚠ Shroud transparent for clarity

14.

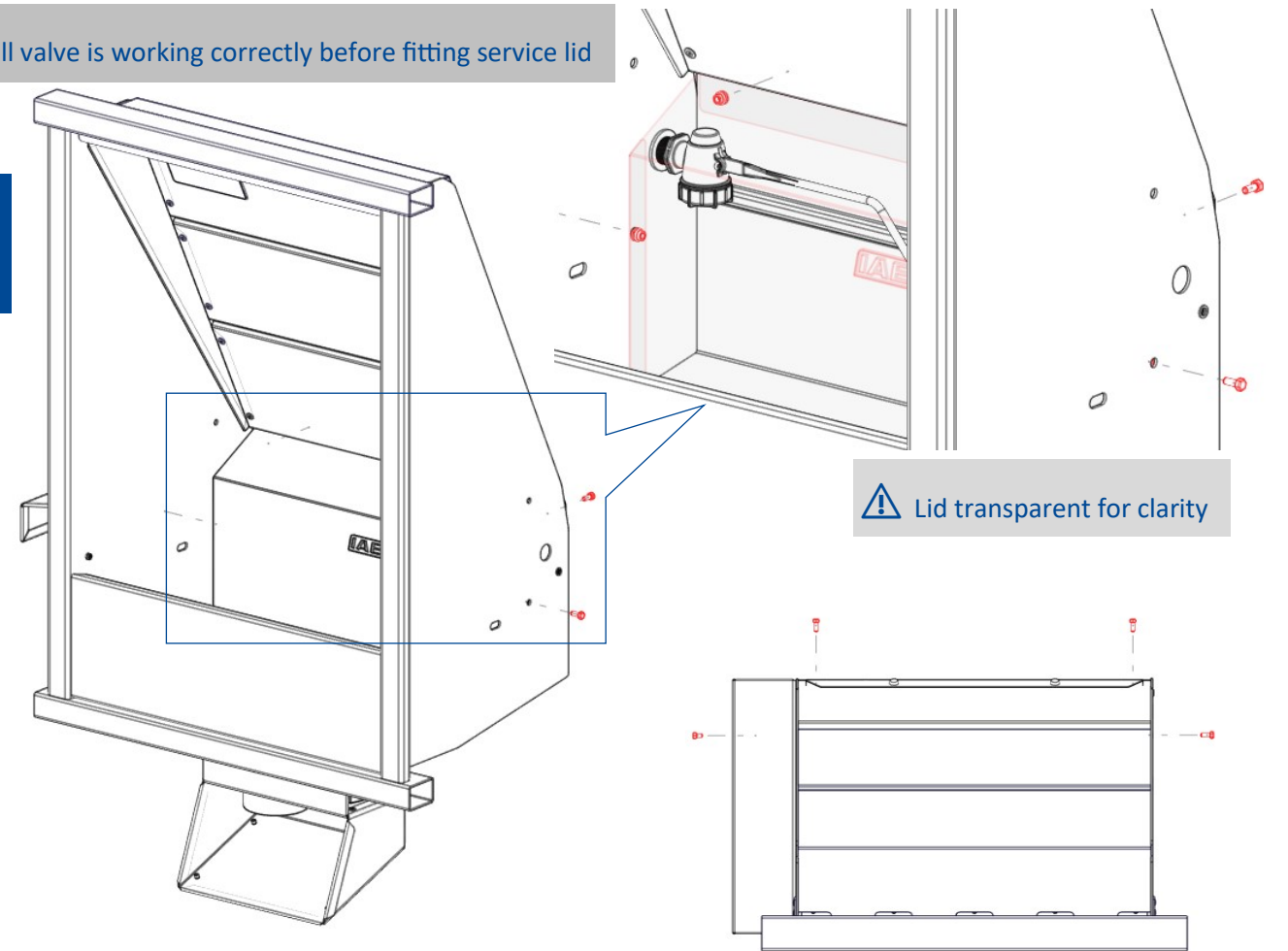

14 - Fit service lid using x4 M6x10 setscrews (built-in nutserts to suit on either side and back of trough body)

⚠ Lid transparent for clarity

15.

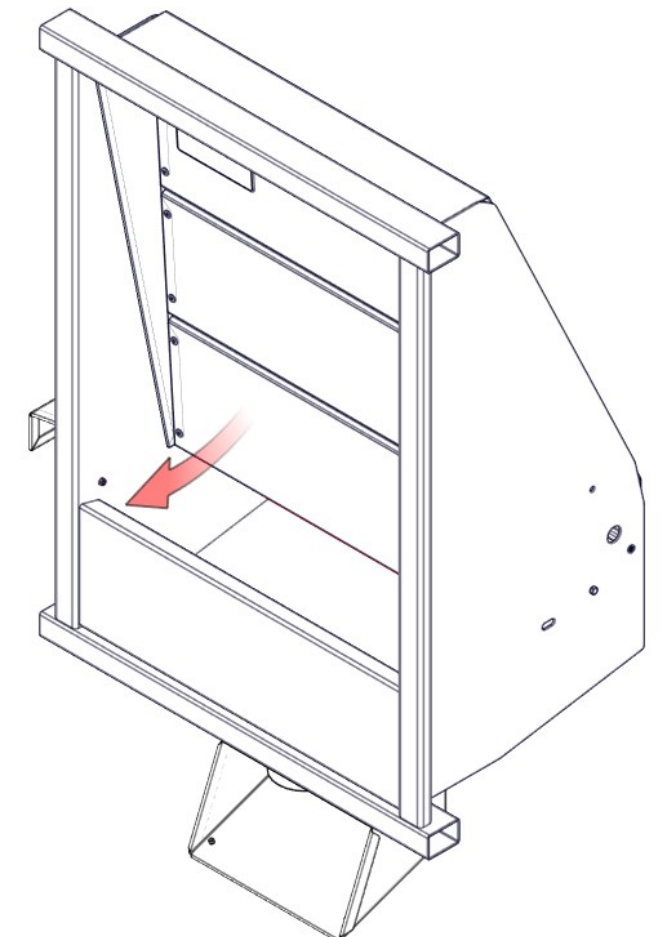

⚠ IMPORTANT to allow settling in period
Initially leave visor in the held back position to allow cattle to adapt to the water supply

15 - Release the visor to complete install

Maintenance & Storage

General Guidance

Although IAE equipment is designed to withstand adverse weather conditions and to withstand prolonged heavy usage, monthly inspections and regular maintenance will help to extend the longevity of the product. The following checklist may be useful:

- Check steel framework for any signs of corrosion, distortion or wear. Replace or repaired; Any damage to steelwork (i.e. exposed bare metal) should be made good by rubbing down and applying 1 no coat of Galvafruid and 1 no coat of oil based paint.
- Pressure wash or steam wash all equipment after each usage.
- Lubricate all moving parts at regular intervals.
- Check all nuts, bolts & set screws, pay particular attention to the nyloc nuts, over time the nylon contained can degrade - replace nylocs if required.

Hot Dip Galvanising

All IAE products (unless stated otherwise) are Hot Dip Galvanised to the standard of BS EN ISO 1461

Paint & Protective Systems

The Galvanizers Association (www.hdg.org.uk) have conducted field tests with galvanised steel samples throughout the U.K. and identified localised corrosion rates within 10 mile squares.

The results of their tests indicate that steelwork of 3mm and 5mm thick. Hot Dip Galvanized to BS EN 1461: 1999 giving a coating thickness of 55 and 70 microns respectively, typically provides protection against corrosion in excess of 25 years.